

C35[™] Amplified Telephone



E
N
G
L
I
S
H

TABLE OF CONTENTS

Introduction	3
Parts Checklist	4
Quick Reference Guide	5
Connecting the phone	7
Introduction to Clarity Power.....	8
Clarity Power Boost.....	8
Getting Started	
Installing backup batteries	9
Desktop and Wall Mount Installations	10
Placing and receiving calls.....	13
Features	
Memory Storage.....	13
Adding a memory location.....	13
Notification Options	15
Troubleshooting	17
Technical Specifications	19
Safety Instructions	20
FCC Requirements and Regulations	22
Warranty and Service	25

INTRODUCTION

Thank you for purchasing the Clarity C35 Amplified Telephone.

Operating Instructions and the associated Quick Reference Guide will provide you with the information you need to use your C35 effectively, easily and safely. Read this manual thoroughly before using your telephone.

Keep the manual near the telephone for easy reference.

CONTENTS & PARTS CHECKLIST



Handset

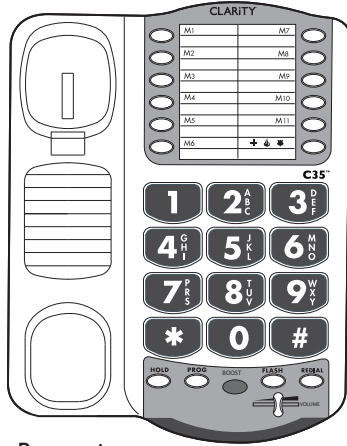

Base unit

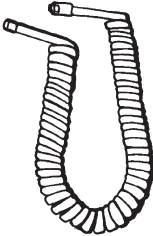

Handset coil cord



Telephone line cord



Mounting bracket



User guide

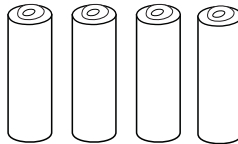

4 AA batteries

FEATURES

- | | |
|---------------------------------|--------------------------|
| 1 Phone Number Directory | 9 BOOST Indicator |
| 2 Memory Button | 10 Hold Indicator |
| 3 Redial Button | 11 Program Button |
| 4 Flash Button | 12 Hold Button |
| 5 Volume Slider | |
| 6 Low Battery Indicator | |
| 7 Visual Ringer | |
| 8 Boost Button | |

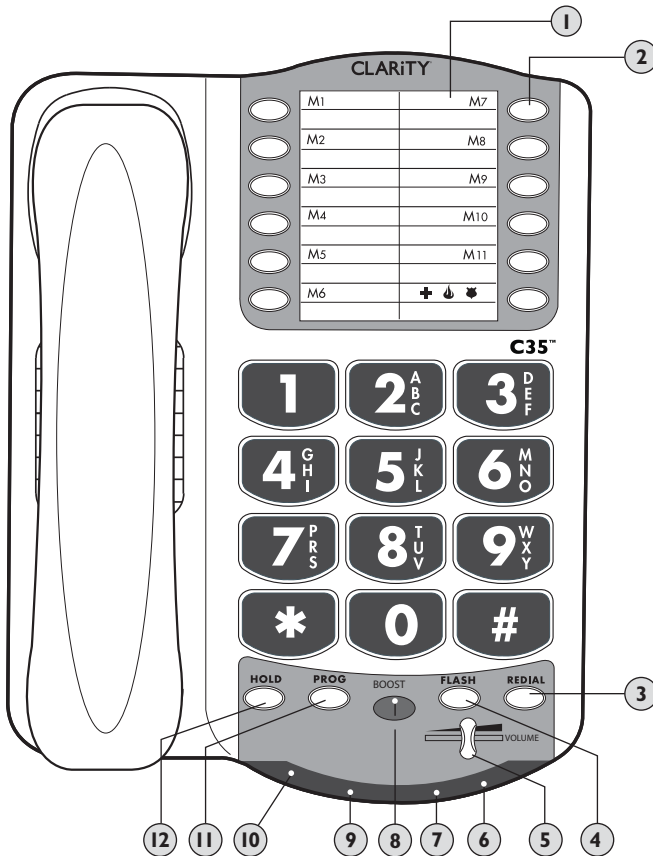

FEATURES

- 1 Ringer Volume Switch
- 2 Pulse/Tone Switch
- 3 Phone Line Connection

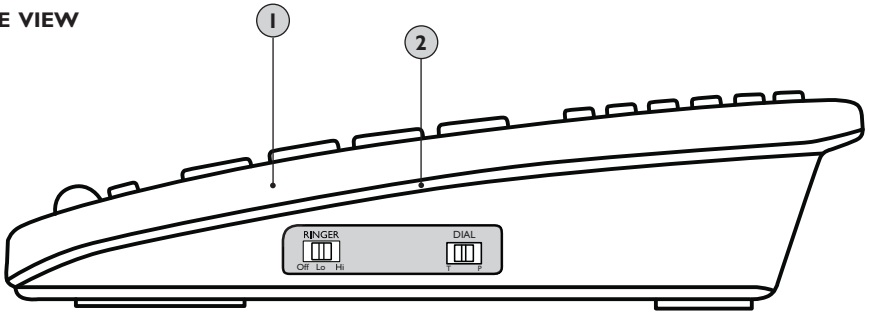
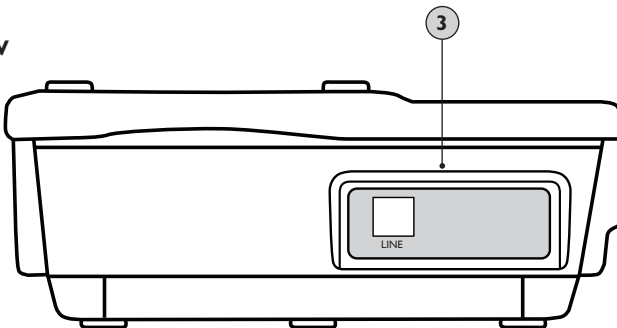
SIDE VIEW**BACK VIEW**

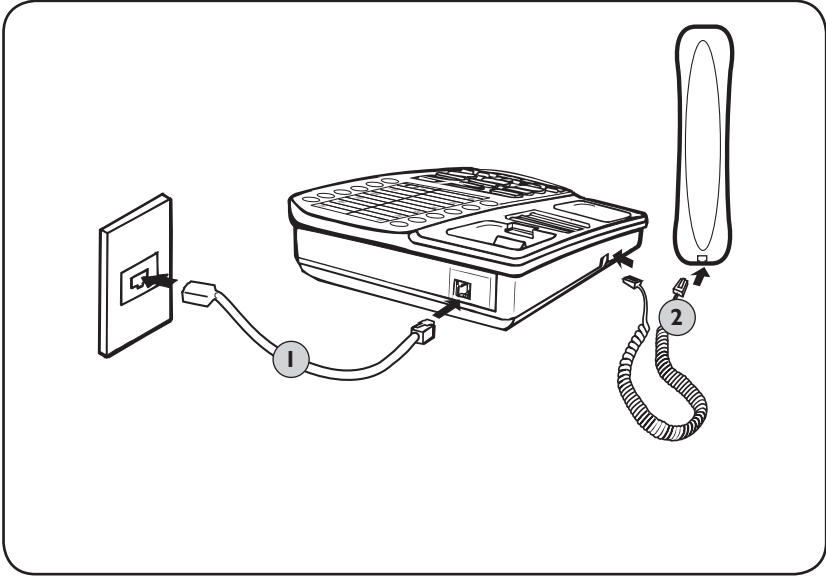
HOW TO CONNECT THE C35 PHONE FOR DESKTOP USE

1. Install the 4 AA batteries.
2. Connect one end of the telephone line cord to the “Line” jack on the back of the C35 and the other end to the phone outlet on your wall.
3. Connect the handset cord to the telephone as shown above.
4. Lift the handset and listen for a dial tone. The phone is ready to use.

*The C35 phone may also be used as a wall mounted phone.
(Please see page 12 of this guide for instructions.)*

INTRODUCTION TO CLARITY POWER

Clarity Power™ Technology

Clarity Power not only makes calls louder, but also easier to understand. The patented Clarity Power technology amplifies and shapes high frequencies to enhance communications for the millions of people who experience high frequency hearing loss, the most common type of hearing loss.

The Clarity C35 has a maximum amplification level of 40dB louder than a regular telephone when the included batteries are inserted. This combined with Clarity Power enhances the sounds being heard through the telephone line, resulting in comfortable and enjoyable conversations.

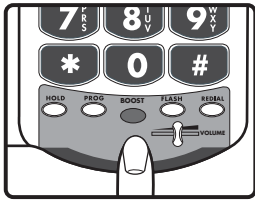

Figure A

Clarity Power BOOST Button

The C35 has a BOOST button that controls the loudness of the receiver. See Figure A. Once the BOOST button is pressed, an extra level of amplification is added over the entire range of the Volume Control. During a call, the BOOST button can toggle the Clarity Power function on or off according to the user's needs. The BOOST button will reset automatically every time the phone is hung up for at least 5 seconds. The BOOST light will illuminate while the BOOST function is activated. See Page 13.

Warning: Volume may be at a high level. To protect hearing, lower the Clarity Power Volume Control before using the phone.

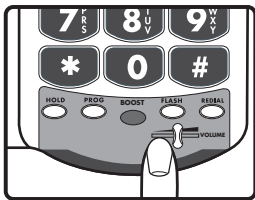

Figure B

Clarity Power Volume Control

The Clarity Power Volume Control adjusts the level of volume the handset both in Boost or non-Boost modes. The volume dial provides up to 15dB of volume before the BOOST button is activated. Once the BOOST button is pressed, the C35 will provide up to 40dB of gain when the batteries are inserted. See Figure B.

GETTING STARTED

There are four initial steps involved in setting up your C35

1. Insert four AA alkaline batteries for maximum amplification. See below.
2. Decide if you want the phone to sit on a desk or hang on the wall.
3. Connect the telephone components. Pages 11-12.
4. Program up to twelve (12) telephone numbers to call with the press of a memory button. See Page 13.

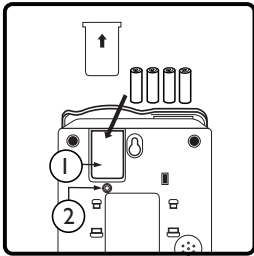

Figure 1

To install new batteries:

1. Slide open the battery compartment cover on the bottom of the telephone. This opening is pointed out with the #2 in Figure 1. To open the battery compartment, use a pen or similar fine point instrument to press into small opening below the compartment door.
2. Install four fresh batteries. Be sure to observe battery polarity as imprinted on the base of the compartment. The battery indicator on the top panel will light up if the batteries are running low.

The batteries are required to reach the maximum amplification and to fully operate certain functions on the phone. If the low battery indicator appears, please replace with new batteries.

GETTING STARTED

Connecting your Telephone

1. Carefully remove your telephone from its box. If there is any visible damage, do not attempt to operate this equipment. Return it to the place of purchase.
2. Check to be sure that you have all items that come with your C35 telephone. You should have a Handset, Base Unit, Mounting Bracket, Handset Line Cord, and Telephone Line Cord, User Guide and 4 AA batteries.

Choosing a Location

- The C35 requires a modular phone jack
- The unit should be located in an area where it is easy to see the lighted ringer.
- Choose a location that is out of the way of normal activities.
- The unit can be used as a desk top phone or wall mount phone.

Desk Mounting Instructions

Follow these instructions to place the phone on a desk or table top using the supplied bracket.

1. Plug one end of the long flat telephone line cord into the jack marked LINE located on the back of the telephone. Plug the other end into the telephone wall jack. See Figure 2
2. Plug one end of the modular coiled handset cord into the handset. Plug the other end into the jack located on the left side of the telephone. Place the handset in the cradle. See Figure 3.

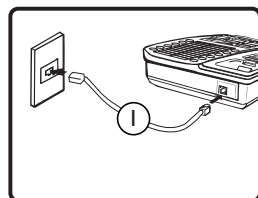

Figure 2

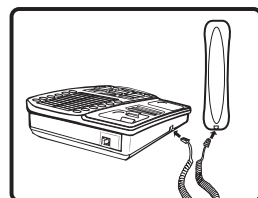

Figure 3

GETTING STARTED

3. Set the TONE/PULSE switch located on the right side of the base to correct dialing mode. Please check with your local telephone company if uncertain of the type of service.
4. Lift the handset and listen for a dial tone. The phone is ready to use.

Wall Mounting Instructions

The phone unit may be mounted on a standard wall plate. The mounting bracket will mount on the telephone with the larger tabs towards the bottom of the phone.

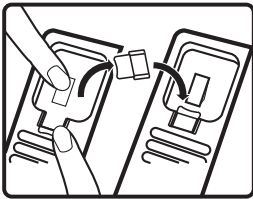

Figure 4

1. Pull the handset hook out of the base and reverse its position so that the hook points up and will hold the handset when you hang up. See Figure 4.
2. Plug one end of the short flat telephone line cord into the jack marked LINE located on the back of the telephone. Then run the cord through the groove on the back of the phone.
3. Insert the tabs of the mounting bracket into the slots in the back of the phone. Push the mounting bracket in and down firmly until it snaps into place. See Figure 5.

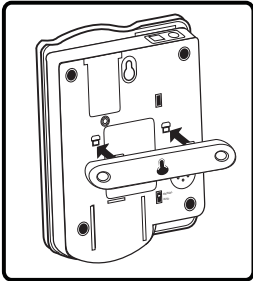

Figure 5

GETTING STARTED

4. Plug the flat telephone line cord into the wall plate jack, then align the mounting bracket's keyhole slots with the wall plate studs and slide the base of the phone downward to secure it on the wall. See Figure 6.
5. Plug one end of the coiled handset cord into the bottom of the handset. Plug the other end of the handset into the modular jack marked **HANDSET** located on the left side of the phone. Place receiver in the cradle. See Figure 7.
6. Set the **TONE/PULSE** switch located on the back of the base to correct dialing mode. Please check with your local telephone company if uncertain of the type of service.
7. Locate the small hook on the handset cradle on the base. Pull the hook out and turn around so the small lip faces upward to support the handset.
8. Lift the handset and listen for a dial tone. The phone is ready to use.

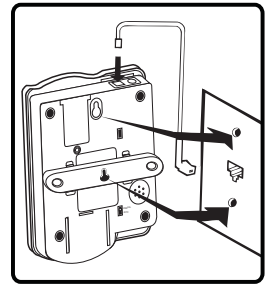

Figure 6

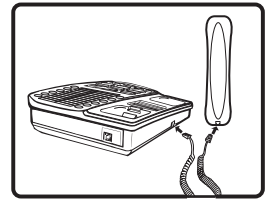

Figure 7

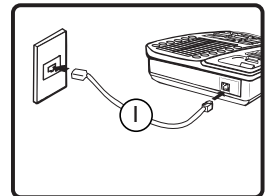

Figure 8

1. Plug one end of the long flat telephone line cord into the jack marked **LINE** located on the back of the telephone.

TELEPHONE OPERATIONS

Placing a Call

1. Lift the handset and dial the number you wish to call.
2. Press the BOOST button and turn the Clarity Power slider to adjust volume. The BOOST button will illuminate to indicate amplification is on.

Receiving a Call

When a call is received, the audible ringer will sound and the visual ringer will flash to alert you of an incoming call. To answer the call, lift the handset.

FEATURES

Memory Storage

Phone numbers can be stored into the phone's memory to enable one-button dialing. The phone directory allows space for twelve (12) different phone numbers. One space is marked to be used to store an emergency number. See Figure 9.

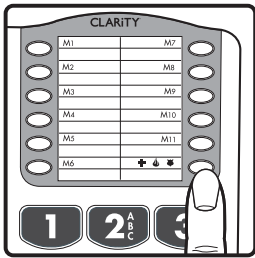

Figure 9

It is important to not store 911 into your phone.

This will prevent inadvertently calling an emergency call center. Only store emergency numbers such as a doctor, hospital, the local fire department or local police station numbers.

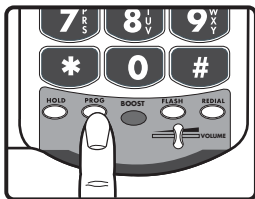

Figure 10

Adding a Memory Location

1. Pick up the handset.
2. Press the PROG button. See Figure 10.
3. Enter the telephone number you wish to store.
4. Press the PROG button.
5. Press the desired memory location (M1 - M11 and Emergency) to store the number to.
6. Place the handset back in the cradle.

Note: No audio notification will occur after the number has been stored properly.

To change a Memory Location, reprogram using the same procedure with the button to be changed.

TELEPHONE OPERATIONS

Dialing a Memory Location

1. Pick up the handset.
2. Press the memory button where the desired number has been stored.
3. The call will automatically dial.

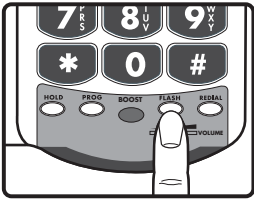

Figure 11

Flash

Flash is a feature that enables you to answer a call if you have call waiting. Please contact your local telephone company for information on subscribing to this feature. Pressing the FLASH button while you are having a phone conversation will pick up the second conversation and place the first call on hold. Press the FLASH button again to continue your conversation with the first caller. See Figure 11.

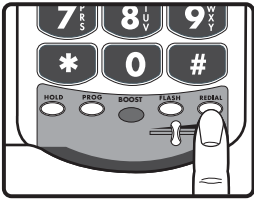

Figure 12

Last Number Redial

Redial allows you to automatically redial the last telephone number you called (up to 32 digits). To use this feature, listen for dial tone and press the REDIAL button once. Your call will be dialed. The last number dialed will be stored in the C35 for you until you dial another phone number. See Figure 12.

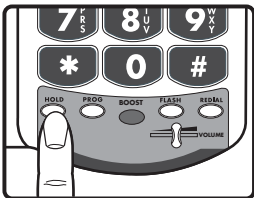

Figure 13

Hold

To put the line on hold, press the HOLD button and return the handset to its cradle. You will notice the HOLD indicator light comes on. To take the phone call off HOLD, press the HOLD button again. See Figure 13.

Note: If you pick up an extension phone on the same line when the C35 is on HOLD, the C35 will release the HOLD, and you can continue your conversation on the

TELEPHONE OPERATIONS

extension phone.

NOTIFICATION OPTIONS

Ringer Volume

Ringer Volume can be set to one of three (3) positions by pressing the RINGER VOLUME UP or DOWN switch located on the right side of the telephone. See Figure 14.

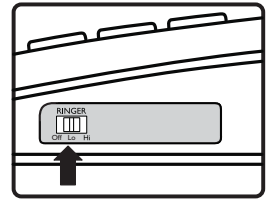

Figure 14

C35 Low Battery Indicator

If the batteries are weak, the Low Battery indicator will light up. Install fresh batteries according to the directions above. See Figure 15.

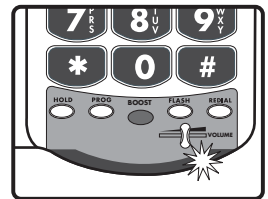

Figure 15

The batteries are required to reach the maximum amplification and to fully operate certain functions on the phone.

Visual Ringer

The visual ringer LED lights up during an incoming call. See Figure 16.

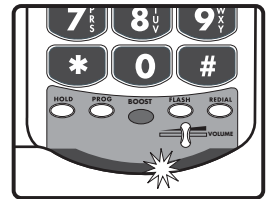
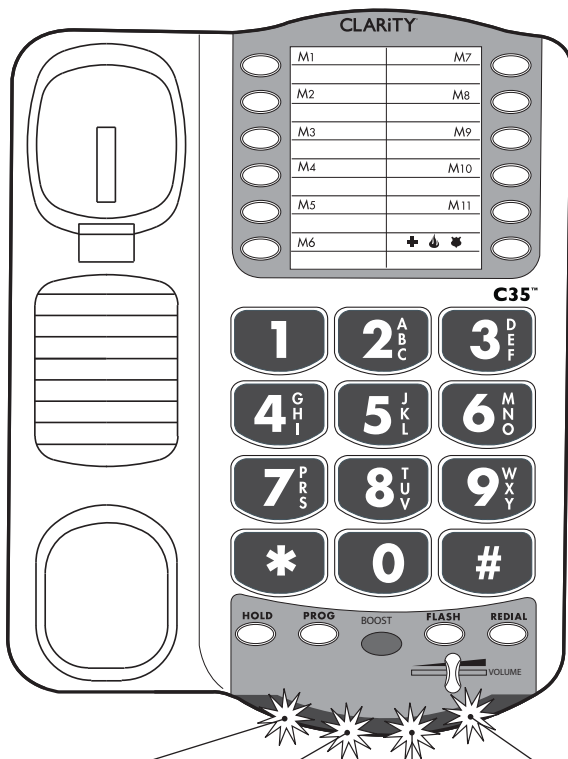

Figure 16

PHONE INDICATOR LIGHTS



HOLD Indicator Light

This light will illuminate when the phone call is put on HOLD. To take off of HOLD, press the HOLD button again.

BOOST Indicator

This light will illuminate when the BOOST feature is activated.

Visual Ringer

The visual ringer will flash to alert of an incoming call.

Low Battery Indicator

This light will illuminate to indicate the battery power is low. The batteries should be replaced to allow the phone to be fully functional in case the phone stops receiving power.

TROUBLESHOOTING

No Dial Tone/Phone Will Not Operate

1. Check all phone cords and connections. Make sure they are plugged in securely.
2. Plug unit into a different phone jack to help determine if the difficulty is with the phone or the phone jack.
3. Switch out handset or telephone line cords.
4. Disconnect any other equipment that may be attached to the phone.

Unable To Dial Out

1. Make sure TONE/PULSE switch is set correctly.
2. Phone may be at the end of a long line of phones (loop). Phone may not be getting enough power from the phone line. It may be necessary to wait for a few seconds after lifting the handset to begin dialing.
3. The C35 is not compatible with Digital PBX Systems. If a standard, single line phone works on the system, your C35 should also.

The Person On The Other End Cannot Hear You

1. Too many phones or phone devices on the line may effect your phone's transmission. As a guideline, more than five (5) phones or phone devices may overload the phone line. Disconnect one (1) or two (2) devices to see if that eliminates the problem. If not, contact your local phone company for load guidelines.
2. You may not be speaking directly into the transmitter. Always speak directly into the mouth piece in your normal tone of voice.

TROUBLESHOOTING

Unable To Hear Phone Ringer

1. Too many phone or phone devices on a line may cause your phone to not ring. Disconnect one (1) or two (2) of the devices to see if the problem is eliminated. If not, contact your local phone company for load guide lines.
2. If batteries are not placed in the phone, the extra loud ringer, will not work.

Volume Control Does Not Work

BOOST must be activated to turn on the additional amplification.

Static On The Line

1. Your phone may be located near a touch lamp, microwave, refrigerator or other household appliances. Try relocating your phone to another area.
2. A cordless phone on your line may cause static. Try disconnecting the cordless phone. This may eliminate the problem.
3. Extra devices attached to the telephone, such as CID units and answering machines may cause static. Disconnecting the devices may eliminate the problem.
4. If there is also a DSL service in the home, this will cause interference on the line. That interference is then amplified by the phone, causing a less than optimal quality of conversation. Install the phone line filter provided by the DSL service provider to reduce the amount of interference on the line.

Interference

1. Check cords and connections. Frayed or poorly connected cords can cause interference. Swap cords if necessary.
2. A RFI (Radio Frequency Interference) filter can be placed on the line to help minimize or eliminate radio or CB transmissions. Try relocating the telephone to another area.

TROUBLESHOOTING

Unable to Access Automated Systems

Automated systems used by banks, long distance voice mail and other applications require that a phone be set to “tone” dialing. Check the switch on the back of the phone labeled “T/P” and set to “T.” This will enable the phone to be compatible with these automated systems. Compatibility

Do I Need to Install Batteries?

To reach the maximum amplification of 40dB, and to fully operate certain functions on the phone, the batteries need to be installed. This phone uses four (4) AA batteries.

Still Not Working?

If, after going through this checklist, the C35 is still not functioning properly, call Clarity at 1-800-426-3738.

TECHNICAL SPECIFICATIONS

Amplified dB Level

40dB/118 dB SPL

Dimensions

Size: 9 1/2" x 7" x 3 1/4" (24.13cm x 17.78cm x 8.25cm)

Weight: 2.52 lbs. (1.14 kg)

Power Requirements

Batteries: 4 AA alkaline batteries (included)

IMPORTANT SAFETY INSTRUCTIONS

When using your telephone equipment, basic safety precautions should always be followed to reduce the risk of fire, electric shock and injury to persons including the following:

1. Read and understand all instructions.
2. Follow all warnings and instructions marked on the telephone.
3. Do not use this telephone near a bathtub, wash basin, kitchen sink or laundry tub, in a wet basement, near a swimming pool or any where else there is water.
4. Avoid using a telephone (other than a cordless type) during a storm. There may be a remote risk of electrical shock from lightning.
5. Do not use the telephone to report a gas leak in the vicinity of the leak.
6. Unplug this telephone from the wall outlets before cleaning. Do not use liquid cleaners or aerosol cleaners on the telephone. Use a damp cloth for cleaning.
7. Place this telephone on a stable surface. Serious damage and/or injury may result if the telephone falls.
8. Do not cover the slots and openings on this telephone. This telephone should never be placed near or over a radiator or heat register. This telephone should not be placed in a built-in installation unless proper ventilation is provided.
9. Operate this telephone using the electrical voltage as stated on the base unit or the owner's manual. If you are not sure of the voltage in your home, consult your dealer or local power company.
10. Install the telephone where no one will step or trip on the cord.
11. Do not overload wall outlets or extension cords as this can increase the risk of fire or electrical shock.
12. Never push any objects through the slots in the telephone. They can touch dangerous voltage points or short out parts that could result in a risk of fire or electrical shock. Never spill liquid of any kind on the telephone.
13. To reduce the risk of electrical shock, do not take this phone apart. Opening or removing covers may expose you to dangerous voltages or other risks. Incorrect reassembly can cause electric shock when the appliance is subsequently used.
14. Unplug this product from the wall outlet and refer servicing to the manufacturer under the following conditions:
 - A. When the phone cord or plug is frayed or damaged.
 - B. If liquid has been spilled into the product.
 - C. If the telephone has been exposed to rain or water.
 - D. If the telephone does not

SAVE THESE INSTRUCTIONS

IMPORTANT SAFETY INSTRUCTIONS

operate normally by following the operating instructions. Adjust only those controls that are covered by the operating instructions. Improper adjustment may require extensive work by a qualified technician to restore the telephone to normal operation.

E. If the telephone has been dropped or the case has been damaged.

F. If the telephone exhibits a distinct change in performance.

15. Never install telephone wiring during a lightning storm.
16. Never install telephone jacks in wet locations unless the jack is specifically designed for wet locations.
17. Never touch uninsulated telephone wires or terminals unless the telephone line has been disconnected at the network interface.
18. Use caution when installing or modifying telephone lines.

2. Do not dispose of the battery in a fire as it may explode. Check with local codes for possible special disposal instructions.
3. Do not open or mutilate the battery. Released electrolyte is corrosive and may cause damage to the eyes and skin. It may be toxic if swallowed.
4. Exercise care in handling batteries in order not to short the battery with conducting materials such as rings, bracelets and keys. The battery or conduction material may over-heat and cause burns.
5. Observe proper polarity orientation between the battery pack and the battery charger.

SAFETY INSTRUCTIONS FOR BATTERIES

Caution: Risk of explosion if battery is replaced by an incorrect type.

Dispose of used batteries according to the instructions.

1. Use only 4 AA alkaline batteries.

For Base Unit:

Four (4) AA alkaline batteries

SAVE THESE INSTRUCTIONS

REGULATORY COMPLIANCE

Part 68 of FCC Rules Information

a) This equipment complies with Part 68 of the FCC rules and the requirements adopted by the ACTA. On the bottom of this equipment is a label that contains, among other information, a product identifier in the format US:AAAEQ##TXXXX. If requested, this number must be provided to the telephone company.

b) A plug and jack used to connect this equipment to the premises wiring and telephone network must comply with the applicable FCC Part 68 rules and requirements adopted by the ACTA. A compliant telephone cord and modular plug, RJ11C USOC, is provided with this product. It is designed to be connected to a compatible modular jack that is also compliant. See installation instructions for details.

c) The REN is used to determine the number of devices that may be connected to a telephone line. Excessive RENs on a telephone line may result in the devices not ringing in response to an incoming call. In most but not all areas, the sum of RENs should not exceed five (5.0). To be certain of the number of devices that may be connected to a line, as determined by the total RENs, contact the local telephone company. For products approved after July 23, 2001, the REN for this product is part of the product identifier that has the format US:AAAEQ##TXXXX.

The digits represented by ## are the REN without a decimal point (e.g., 03 is a REN of 0.3). For earlier products, the REN is separately shown on the label.

d) If this telephone equipment causes harm to the telephone network, the telephone company will notify you in advance that temporary discontinuance of service may be required. But if advance notice isn't practical, the telephone company will notify the customer as soon as possible. Also, you will be advised of your right to file a complaint with the FCC if you believe it is necessary.

e) The telephone company may make changes in its facilities, equipment, operations or procedures that could affect the operation of the equipment. If this happens the telephone company will provide advance notice in order for you to make necessary modifications to maintain uninterrupted service.

f) If trouble is experienced with this telephone equipment, for repair or warranty information, please contact Clarity, 1-800-552-3368. If the equipment is causing harm to the telephone network, the telephone company may request that you disconnect the equipment until the problem is resolved.

g) This telephone equipment is not intended to be repaired and it contains no repairable parts. Opening the equipment or any attempt to perform repairs will void the warranty. For service or repairs, call 1-800-552-3368.

h) Connection to party line service is subject to state tariffs. Contact the state public utility commission, public service commission or corporation commission for information.

REGULATORY COMPLIANCE

i) If your home has specially wired alarm equipment connected to the telephone line, ensure the installation of this telephone equipment does not disable your alarm equipment. If you have questions about what will disable alarm equipment, consult your telephone company or a qualified installer.

j) This telephone equipment is hearing aid compatible.

Customer-Owned Coin/Credit Card Phones:

To comply with state tariffs, the telephone company must be given notification prior to connection. In some states, the state public utility commission, public service commission or corporation commission must give prior approval of connection.

Part 15 of FCC Rules Information

This device complies with Part 15 of the FCC Rules. Operation is subject to the following two conditions: (1) This device may not cause harmful interference, and (2) this device must accept any interference received, including interference that may cause undesired operation.

Your equipment has been tested and found to comply with the limits of a Class B digital device, pursuant to Part 15 of FCC rules. These limits are designed to provide reasonable protection against harmful interference in residential installation.

This equipment generates, uses and can radiate radio frequency energy and, if not installed and used in accordance with the instructions, may cause harmful interference to radio communications. However, there is no guarantee that interference will not occur in a particular installation; if this equipment does cause harmful interference to radio or television reception, which can be determined by turning the equipment off and on, you are encouraged to try to correct the interference by one of the following measures:

1. Where it can be done safely, reorient the receiving television or radio antenna.
2. To the extent possible, relocate the television, radio or other receiver with respect to the telephone equipment. (This increases the separation between the telephone equipment and the receiver.)
3. Connect the telephone equipment into an outlet on a circuit different from that to which the television, radio, or other receiver is connected.
4. Consult the dealer or an experienced Radio/TV Technician for help.

CAUTION: Changes or modifications not expressly approved by the manufacturer responsible for compliance could void the user's authority to operate the equipment.

REGULATORY COMPLIANCE

Industry Canada Technical Specifications

This product meets the applicable Industry Canada technical specifications.

Before installing this equipment, users should ensure that it is permissible to be connected to the facilities of the local telecommunications company. The equipment must also be installed using an acceptable method of connection. In some cases, the company's inside wiring associated with a single line individual service may be extended by means of a certified connector assembly (telephone extension cord). The customer should be aware that compliance with the above conditions may not prevent degradation of service in some situations. Repairs to certified equipment should be made by an authorized Canadian maintenance facility designated by the supplier.

Any repairs or alterations made by the user to this equipment, or equipment malfunctions, may give the telecommunications company cause to request the user to disconnect the equipment.

Users should ensure for their own protection that the electrical ground connections of the power utility, telephone lines and internal metallic water pipe system, if present, are connected together. This precaution may be particularly important in rural areas.

CAUTION: Users should not attempt to make such connections themselves, but should contact the appropriate electrical inspection authority, or electrician, as appropriate.

The Ringer Equivalence Number is an indication of the maximum number of terminals allowed to be connected to a telephone interface. The termination on an interface may consist of any combination of devices subject only to the requirement that the sum of the Ringer Equivalence Numbers of all the devices does not exceed five.

(The term "IC:" before the certification/registration number only signifies that the Industry Canada technical specifications were met.)

The party responsible for regulatory compliance:

Clarity, A Division of Plantronics, Inc.
4289 Bonny Oaks Drive, Suite 106
Chattanooga, TN 37406
Phone: 1-800-552-3368

WARRANTY & SERVICE

The following warranty and service information applies only to products purchased and used in the U.S. and Canada. For warranty information in other countries, please contact your local retailer or distributor.

Limited Warranty

Clarity, a division of Plantronics, Inc. (“Clarity”) warrants to the original consumer purchaser that, except for limitations and exclusions set forth below, this product shall be free from defects in materials and workmanship for a period of one (1) year from the date of original purchase (“Warranty Period”). The obligation of Clarity under this warranty shall be at Clarity’s option, without charge, of any part or unit that proves to be defective in material or workmanship during the Warranty Period.

Exclusions from Warranty

This warranty applies only to defects in factory materials and factory workmanship. Any condition caused by accident, abuse, misuse or improper operation, violation of instructions furnished by Clarity, destruction or alteration, improper electrical voltages or currents, or repair or maintenance attempted by anyone other than Clarity or an authorized service center, is not a defect covered by this warranty. Telephone

companies manufacture different types of equipment and Clarity does not warrant that its equipment is compatible with the equipment of a particular phone company.

Implied Warranties

Under state law, you may be entitled to the benefit of certain implied warranties. These implied warranties will continue in force only during the warranty period. Some states do allow limitations on how long an implied warranty lasts, so the above limitation may not apply to you.

Incidental or Consequential Damages

Neither Clarity nor your retail dealer or selling distributors has any responsibility for any incidental or consequential damages including without limitation, commercial loss or profit, or for any incidental expenses, expenses, loss of time, or inconvenience. Some states do not allow exclusion or limitation of incidental or consequential damage, so the above limitation or exclusion may not apply to you.

Other Legal Rights

This warranty gives you specific legal rights and you may also have other rights which vary from state to state.

WARRANTY & SERVICE

How to Obtain Warranty Service

To obtain warranty service, please prepay shipment and return the unit to the appropriate facility listed below.

In the United States

Clarity Service Center
4289 Bonny Oaks Drive, Suite 106
Chattanooga, Tennessee 37406

Tel: (423) 622-7793 or
(800) 426-3738
Fax: (423) 622-7646 or
(800) 325-8871

In Canada

Plantronics Service Center
8112 Trans-Canada Hwy.
Ville St. Laurent. Que.
Canada H4S 1M5

Tel: (800) 540-8363
(514) 956-8363
Fax: (514) 956-1825

Please use the original container, or pack the unit(s) in a sturdy carton with sufficient packing material to prevent damage.

Include the following information:

1. A proof-of-purchase indicating model number and date of purchase.
2. Bill-to address.
3. Ship-to address.
4. Number and description of units shipped.
5. Name and telephone number of person to call, should contact be necessary.
6. Reason for return and description of the problem.

Damage occurring during shipment is deemed the responsibility of the carrier, and claims should be made directly with the carrier.