

User Guide

SMART FOR SENIORS™

Clarity Pal™ Amplified Mobile Phone



Table of Contents

BASIC INFORMATION

Safety and Maintenance and Care	1-6
Warranty Information.....	7-8
FCC Regulations	9-10

FEATURES OVERVIEW

Keys/Buttons/Features.....	11-12
LCD Status Icons.....	13
Technical Specifications.....	13

BATTERY

Installation/Removal	14
Charging.....	14
Use.....	15
Security.....	15

NETWORK SETUP

SIM Card Information	16
Inserting/Removal SIM Card	16
Locking SIM Card	16
Locking the phone.....	17
Connecting to Network.....	17
Power On/OFF.....	17

PHONE MENU OVERVIEW

Overview	18-23
----------------	-------

OPERATIONS

Making a call.....	24
Dialing Status	24
Connecting Status	24
National calls	25
International calls	25
Calling to an extension	24
Calls from lists.....	25

Table of Contents

Emergency calls.....	25
Conversations	25
Function operation	26
Call options	26
Use of TONE Key during conversations	26
Auto DTMF	26
Auto Response.....	26

Function Menus

Rolling searching functions	26
Personal shortcuts	27
Exit.....	27

Phonebook.....

User Profiles

General mode.....	28
Meeting mode.....	28
Outdoor mode.....	28
Indoor mode.....	28
Headset mode.....	28
Bluetooth mode.....	28
Customizable features	28-29

Messaging (SMS)

Writing a message.....	30-31
Inbox/Outbox.....	31
Templates.....	31
Message Settings.....	31
SMS Settings.....	32

Table of Contents

Messaging (MMS)

Writing a message.....	33
Inbox/Outbox.....	33
Draft Box.....	33
Templates.....	33
Voice Mail-Box.....	33

SETTINGS

Phone Settings.....	34-35
Network Settings.....	36-37

Security Settings 36-37

SIM Card Lock.....	36
Phone Lock.....	36
Keypad Lock.....	36
Changing Password.....	36
Changing PIN code.....	36

ADDITIONAL FUNCTIONS

Restore factory settings.....	38
Bluetooth.....	38

Organizer 38

Calendar.....	38
Stopwatch.....	38
Calculator.....	39

Table of Contents

Shortcuts..... 39

Accessibility..... 39

Language.....	39
Help Settings/SOS.....	39
Recording.....	39-40

Phone calls..... 40

Call history.....	40
Call settings.....	40

Input methods

Input by English.....	42-43
Input by number.....	44-45

TROUBLESHOOTING..... 46

CONTACT INFORMATION 47

Safety and Maintenance Instructions

Please read the following safety instructions before using your Clarity Pal™ Dual Band Mobile Phone and accessories. Please keep these instructions for your reference. When using this product, these safety precautions and warnings should be followed to reduce the risk of fire, electric shock, injury to persons and damage to property. Additional warnings may be present on the product, packaging, or in the user instructions.

WARNINGS

Emergency Call Feature

When the emergency button is pressed the emergency numbers saved in the phone's address book will be called in the order you have selected until a party is reached. Up to five emergency numbers may be saved in the address book. The numbers and the order they will be called must be entered into the phone in order to ensure the desired numbers are dialed when the emergency button is pressed. After you have entered your five emergency numbers, you should test the phone's emergency call feature by pressing the emergency button to ensure that you have correctly entered the numbers into the phone.

Since the phone service must be purchased in advance through monthly pre-paid credits, you must ensure that you have made your pre-payment in order for the phone service to remain activated. If you do not make your monthly pre-payment or if you do not make a full monthly payment, you will lose your phone service, and the

phone and the emergency call feature will not be available.

You must also ensure that the phone's battery is fully-charged at all times and that the phone is in good working condition in order for the emergency call feature to work.

If the phone is outside of a cover-age area, if network service is temporarily suspended by the network carrier, or if there is network or phone interference, the emergency call feature will not be available during those times.

This phone is not equipped with a global positioning service or other means to determine the physical location of the phone. Consequently, if an emergency situation arises but you are unable to provide your location to an emergency contact person in your address book, neither they nor an emergency response service may be able to locate you.

The SIM card must be installed and activated before you will receive any phone service. If the SIM card is damaged or

Safety and Maintenance Instructions

replaced, the emergency contact numbers you entered into the phone will be lost. In that case you must re-enter your five emergency contact numbers into the phone's address book in order to restore the emergency call feature.

After you have re-entered your five emergency numbers, you should test the phone's emergency call feature by pressing the emergency button to ensure that you have correctly entered the numbers into the phone.

RADIO FREQUENCY INTERFERENCE

Pacemakers

The Health Industry Manufacturers Association recommends that a minimum separation of (6) inches be maintained between a handheld wireless phone and a pacemaker to avoid potential interference with the pacemaker. Persons with pacemakers:

- Should always keep the phone more than (6) inches from their pacemaker when the phone is turned on.
- Should not carry the phone in a breast pocket.
- Should use the ear opposite the pacemaker to minimize the potential for interference.

If you have any reason to suspect that interference is taking place, turn the phone off immediately.

Hearing Aids

The phone may interfere with some hearing aids. If it does, consult the hearing aid manufacturer or your physician for alternatives or remedies.

Other Medical Devices

If you use any other personal medical device, consult the device manufacturer or your physician to determine if it is adequately shielded from external (RF) energy.

COMPLIANCE WITH MOBILE PHONE USE RESTRICTIONS

Air Travel

Mobile phone use may be prohibited during air travel.

Posted Signs

Obey posted signs or notices prohibiting mobile phone use in certain locations, including but not limited to blasting areas, health care facilities and aircraft.

Health Care Facilities

Turn the phone off in health care facilities when any regulations posted in these areas

Safety and Maintenance Instructions

instruct you to do so. Hospitals and health care facilities may use equipment that is sensitive to external (RF) energy.

Driving Safely

Check and follow local laws and regulations regarding use of a mobile phone while driving.

If you decide to use a mobile phone while driving a vehicle, give your full attention to driving safely and keep the following driving tips in mind:

- Be responsible behind the wheel. Don't Text and Drive!
- Get to know your wireless device and its features such as speed dial and redial.
- Position your wireless device within easy reach.
- Dial sensibly and assess the traffic; place calls when you are not moving.
- Let the person you are speaking with know you are driving; if necessary suspend the call in heavy traffic or hazardous weather conditions.
- Do not take notes or look up phone numbers while driving.
- Use a hands-free device for convenience and comfort.
- Do not engage in stressful or emotional conversations that might divert your attention from the road.

- Dial 911 or other local emergency numbers to report serious emergencies — it's free from your wireless phone.
- Use your wireless phone to help others in emergencies.
- Call roadside assistance or a special non-emergency wireless number when necessary.

* *Driving Tips used with permission from CTIA-The Wireless Association®*

For Vehicles Equipped with an Air Bag

An air bag inflates with great force. Do not store the phone or any of its accessories in the area over the air bag or in the air bag deployment area.

CHARGER WARNINGS

- Use only those Clarity products and accessories designed for use with this product.
- Do not disassemble the product or AC adapter as this may expose you to dangerous voltages or other risks. Incorrect reassembly can cause electric shock or fire when the product is subsequently used.
- Use only the charger supplied by Clarity to charge the product. Do not use the chargers for any other purpose. Ensure that the voltage rating corresponds to

Safety and Maintenance Instructions

the power supply you intend to use, for example 100-240 V; 50/60 Hz; 0.2 A.

- Never store or use the product or charge the battery where the temperature may fall below 0°C (32°F) or rise above 40°C (104°F).

BATTERY WARNINGS

To avoid the risk of explosion, fire or leakage of toxic chemicals, please observe the following warnings:

- Do not dispose of the product or battery in a fire or heat above 40°C (104°F).
- Do not open, deform or mutilate the battery. There may be corrosive materials which can cause damage to eyes or skin and may be toxic if swallowed.

Removable Battery

This phone contains a removable battery. Change the battery only as directed in this User Manual.

- Always store batteries where children cannot reach them.
- Remove a spent battery promptly. When replacing the battery, use only the battery provided by Clarity.
- Do not allow any battery or its holder to contact metal objects such as keys or coins.

MAINTENANCE AND CARE

This phone is not customer serviceable. Do not attempt to repair or modify the phone. Doing so may result in injury or void your warranty.

Product Cleaning

Use only a slightly damp lint-free cloth to clean the phone. Use of household cleaners, alcohol, or other chemicals may damage your mobile phone.

Handling the Phone

Do not drop, disassemble, open, crush, bend, deform, puncture, shred, microwave, incinerate, paint, or insert foreign objects into the phone.

Discontinue use of your phone and contact Clarity at **1-800-426-3738** if the product overheats, has a damaged cord or plug or if the product has been damaged.

Connecting Accessories

Do not force connectors into ports. In case of experiencing unreasonable resistance when attempting to insert a connector in a port, check for compatibility, obstruction in the port, or a disfigured connector.

Do not insert anything into the phone other than as directed in the user manual because this may cause damage to the internal components or cause injury to you.

USE ENVIRONMENT

Avoiding Water and Wet Locations

Do not use the phone in rain, or near washbasins or other wet locations. Take care not to spill any food or liquid on the phone. In case the phone gets wet, un-plug all cables, turn off the phone before cleaning, and allow it to dry thoroughly before turning it on again. Do not attempt to dry the phone with an external heat source, such as a microwave oven or hair dryer.

Choking Hazard

Never allow children to play with the phone or accessories — small parts may be a choking hazard.

LISTENING LEVEL WARNINGS

Exposure to high volume sound levels may damage your hearing. Although there is no single volume setting that is appropriate for everyone, you should always use your mobile phone with the volume set at moderate levels and avoid prolonged exposure to high volume sound levels. The louder the volume, the less time is required before your hearing could be affected. You may experience different sound levels when using your headset or headphones with different devices. The device you use and its settings affect the level of sound you hear. If you experience

hearing discomfort, you should stop listening to the device through your headset or headphones. To protect your hearing, some hearing experts suggest that you:

1. Set the volume control in a low position before putting the head set or headphones on your ears.
2. Limit the amount of time you use headsets or headphones at high volume.
3. Avoid turning up the volume to block out noisy surroundings.
4. Turn the volume down if the sound from the headset or headphones prevents you from hearing people speaking near you.

Visit www.plantronics.com/healthandsafety for more information on headsets and hearing.

Exposure to Electromagnetic Energy in the Radio Frequency Band

When turned on, this device transmits and receives electromagnetic radiation in the radio frequency (RF) bandwidth through its antenna. By international scientific agreement, the unit of measurement of (RF) energy is the “specific absorption rate”, or SAR. In the United States, the applicable SAR limit for the C900, set by the FCC is 1.60 mW/g (thousandths of watts per gram of mass), or 1.60 W/Kg (watts per kilogram of mass). The maximum SAR exposure measured for the C900 was 0.738 W/Kg when the phone was turned on but not in use (body position), and 0.264 W/Kg when the phone was in use (cheek position). In all cases, the phone was passed by an independent testing facility.

Disposal and Recycling

Check and follow local laws re-garding disposal and recycling of your phone and battery.

Warranty Information

The following warranty and service information applies only to products purchased and used in the U.S. and Canada. For warranty information in other countries, please contact your local retailer or distributor.

Limited Warranty

Clarity, a division of Plantronics, Inc. (“Clarity”) warrants to the original consumer purchaser that, except for limitations and exclusions set forth below, this product shall be free from defects in materials and workmanship for a period of one (1) year from the date of original purchase (“Warranty Period”). The obligation of Clarity under this warranty shall be at Clarity’s option, without charge, of any part or unit that proves to be defective in material or workmanship during the Warranty Period.

Exclusions from Warranty

This warranty applies only to defects in factory materials and factory workmanship. Any condition caused by accident, abuse, misuse or improper operation, violation of instructions furnished by Clarity, destruction or alteration, improper electrical voltages or currents, or repair or maintenance attempted by anyone other than Clarity or an authorized service center, is not a defect covered by this warranty. Telephone companies manufacture different types of equipment and

Clarity does not warrant that its equipment is compatible with the equipment of a particular phone company.

Implied Warranties

Under state law, you may be entitled to the benefit of certain implied warranties. These implied warranties will continue in force only during the warranty period. Some states do allow limitations on how long an implied warranty lasts, so the above limitation may not apply to you.

Incidental or Consequential Damages

Neither Clarity nor your retail dealer or selling distributors has any responsibility for any incidental or consequential damages including without limitation, commercial loss or profit, or for any incidental expenses, loss of time, or inconvenience. Some states do not allow exclusion or limitation of incidental or consequential damage, so the above limitation or exclusion may not apply to you.

Other Legal Rights

This warranty gives you specific legal rights and you may also have other rights which vary from state to state.

Warranty Information

How to Obtain Warranty Service

To obtain warranty service, please prepay shipment and return the unit to the appropriate facility listed to the right.

In the United States

Clarity Service Center
6131 Preservation Drive,
Chattanooga, TN 37416

Tel: (423) 622-7793 or
(800) 426-3738
Fax: (423) 622-7646 or
(800) 325-8871

In Canada

Plantronics Service Center
8112 Trans-Canada Hwy.
Ville St. Laurent. Que.
Canada H4S 1M5

Tel: (800) 540-8363
(514) 956-8363
Fax: (514) 956-1825

Please use the original container, or pack the unit(s) in a sturdy carton with sufficient packing material to prevent damage.

Include the following information:

1. A proof-of-purchase indicating model number and date of purchase.
2. Bill-to address.
3. Ship-to address.
4. Number and description of units shipped.
5. Name and telephone number of person to call, should contact be necessary.
6. Reason for return and description of the problem.

Damage occurring during shipment is deemed the responsibility of the carrier, and claims should be made directly with the carrier.

FCC Regulations and Requirements

Part 15 of FCC Rules Information

This device complies with Part 15 of the FCC Rules. Operation is subject to the following two conditions: (1) This device may not cause harmful interference, and (2) this device must accept any interference received, including interference that may cause undesired operation.

Your equipment has been tested and found to comply with the limits of a Class B digital device, pursuant to Part 15 of FCC rules. These limits are designed to provide reasonable protection against harmful interference in residential installation.

This equipment generates, uses and can radiate radio frequency energy and, if not installed and used in accordance with the instructions, may cause harmful interference to radio communications. However, there is no guarantee that interference will not occur in a particular installation; if this equipment does cause harmful interference to radio or television reception, which can be determined by turning the equipment off and on, you are encouraged to try to correct the interference by one of the following measures:

1. Where it can be done safely, reorient the receiving television or radio antenna.
2. To the extent possible, relocate the television, radio or other receiver with respect to the telephone equipment. *(This increases the separation between the telephone equipment and the receiver.)*

3. Connect the telephone equipment into an outlet on a circuit different from that to which the television, radio, or other receiver is connected.
4. Consult the dealer or an experienced Radio/TV Technician for help.

CAUTION: Changes or modifications to this equipment not expressly approved by the party responsible for compliance could void the user's authority to operate the equipment.

Privacy of communications may not be ensured when using this phone.

CAUTION: To maintain the compliance with the FCC's RF exposure guideline, place the base unit at least 20cm from nearby persons.

For body worn operation, this handset has been tested and meets the FCC RF exposure guidelines when used with the (Plantronics) accessories supplied or designated for this product. Use of other accessories may not ensure compliance with FCC RF exposure guidelines.

Industry Canada Technical Specifications

This product meets the applicable Industry Canada technical specifications.

Before installing this equipment, users should ensure that it is permissible to be connected to the facilities of the local telecommunications company. The equipment

FCC Regulations and Requirements

must also be installed using an acceptable method of connection. In some cases, the company's inside wiring associated with a single line individual service may be extended by means of a certified connector assembly (telephone extension cord). The customer should be aware that compliance with the above conditions may not prevent degradation of service in some situations. Repairs to certified equipment should be made by an authorized Canadian maintenance facility designated by the supplier.

Any repairs or alterations made by the user to this equipment, or equipment malfunctions, may give the telecommunications company cause to request the user to disconnect the equipment.

Users should ensure for their own protection that the electrical ground connections of the power utility, telephone lines and internal metallic water pipe system, if present, are connected together. This precaution may be particularly important in rural areas.

CAUTION: Users should not attempt to make such connections themselves, but should contact the appropriate electrical inspection authority, or electrician, as appropriate.

The Ringer Equivalence Number is an indication of the maximum number of terminals allowed to be connected to a telephone interface. The termination on an interface may consist of any combina-

tion of devices subject only to the requirement that the sum of the Ringer Equivalence Numbers of all the devices does not exceed five.

(The term "IC:" before the certification/registration number only signifies that the Industry Canada technical specifications were met.)

This Class B digital apparatus complies with Canadian ICES-003.

The party responsible for regulatory compliance:

Clarity, A Division of Plantronics, Inc.
6131 Preservation Drive,
Chattanooga, TN 37416
Phone: 1-800-552-3368

Features Overview

- 1 Message Alert Light (Flashes)
- 2 Volume Adjust Buttons (+/-)
- 3 Headset Port
- 4 **M1*** Memory Key – Long-press/Memory (Press key to access and select menu options.)
- 5 **M2** Memory Key
- 6 **M3*** Memory Key – Long-press/Memory (Also press key to access and select menu options – short press.)
- 7 Dial Key (Press to connect call)
- 8 ON/OFF Key (Press/Hold to Power ON/OFF)
- 9 Arrow Key (Menu Scroll)
- 10 TONE Button
- 11 BOOST Button (Amplify)
- 12 AC Adapter Power Port
- 13 Phone Status Icons (LCD Menu)
- 14 AC Power Adapter
- 15 Charging Base
- 16 Emergency Button (Located on back of phone – see page 12)
- 17 SIM Card (Located on back of phone – see page 12)

Important: Before using phone, please read Safety Instructions.

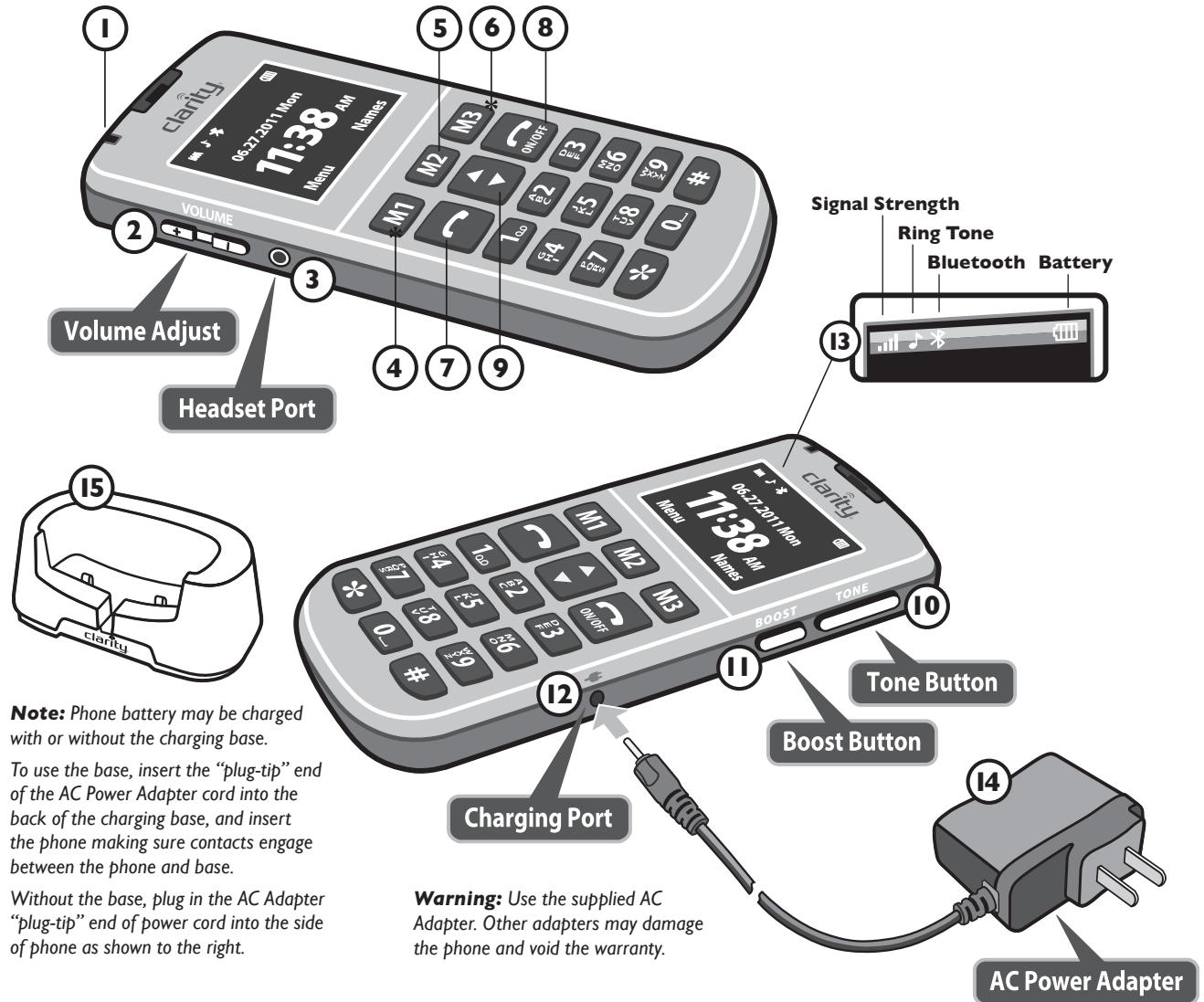

Features Overview

Back Views

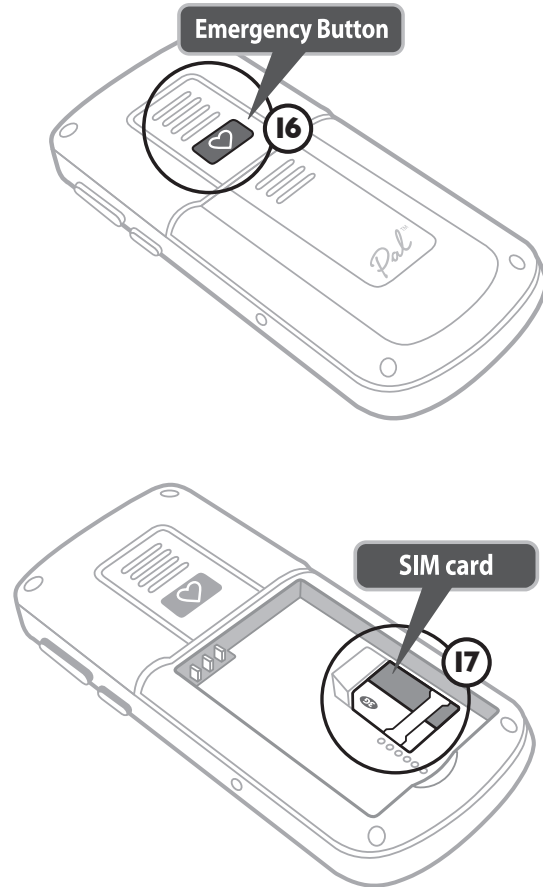

12

LCD Status Icons/Technical Specifications

LCD Status Icons

Signal strength

No signal

GPRS connection

Unread message

Unread service message

Missed calls

Call transfer

Keypad lock

Keypad unlock

Alarm clock

Ring tone

Battery indication

Bluetooth connected

Unread MMS

Headset mode

Technical Specifications

Function	Specification
Model	Pal
Size	5 x 2.5 x .5 in.
SIM type *	Regular
Built-in Memory	506K
Frequency band *	GSM 900 GSM 1800 Dual Frequency
Phonebook	
Capacity *	250pcs (SIM capacity depends on SIM type.)
GPRS *	Support
SMS/MMS	Support
WAP	Support
Bluetooth	Support
Recorder	WAV digital record (Can record ring tones.)
Backlights	Support
Meoldies	Support
Call transfer/call limit *	Support
Call waiting/ conference call *	Support
Alarm/calendar/ world time	Support
Phonebook groups	Support
STK *	Support
Auto redial	Support
Chinese/English input	Support

* This function or service requires network or SIM support.

13

Battery Installation and removal

Step 1: Remove the battery compartment cover by sliding the cover towards the bottom end of the phone.

Step 2: Install the battery by pushing the battery into the compartment while ensuring that the contacts on the battery and battery compartment are correctly aligned and engaged.

Step 3: Replace the battery compartment cover by sliding the cover towards the upper end of the phone. Make sure it snaps securely into place.

Battery charging

Note: Phone Charging Options: See page 11 for correct use of the AC power adapter. The phone may be charged by connecting the AC power cord (tip) directly into the phone's charging port on the side of the phone (see page 11), or by using the charging base with AC power adapter.

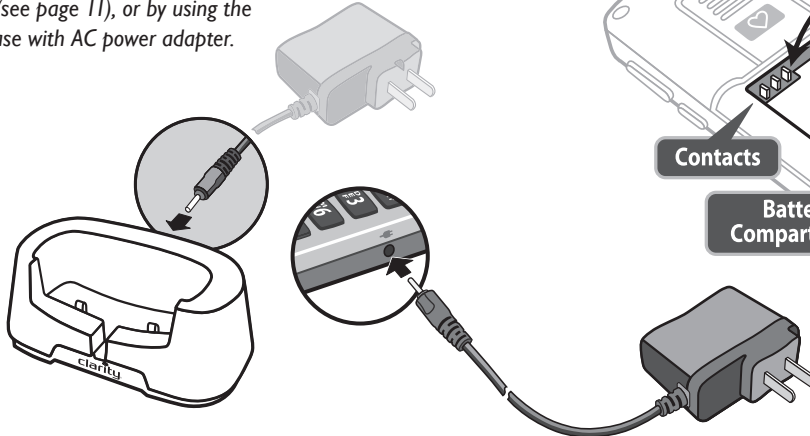

Begin the battery charging process by inserting the “plug-tip” of the AC Power cord into the charging port (11) of the phone. Plug the AC Power Adapter into a 110V electrical outlet. Charging time is approximately 2-3 hours. (See page 11)

The battery indication on the phone LCD will begin to “blink.” If the phone is powered off, the LCD will display “charging.” When charging is complete the battery indicator will stop “blinking.”

Warning: The phone should be stored in a well-ventilated environment where the temperature is -40°C — +55°C. Use only the factory supplied charger and battery.

The warranty will be void if the factory supplied charger is not used.

Battery Use

Recharge the battery when the phone is powered OFF automatically or when there is a low battery indicator showing on the LCD.

If the battery has not completely run out of energy before charging, the mobile will adjust and reduce the time of charging.

The idle and talk time of the phone specified by the factory is based on a perfect working environment. In reality, the working time of the battery will vary with the network status, work environment and usage requirements.

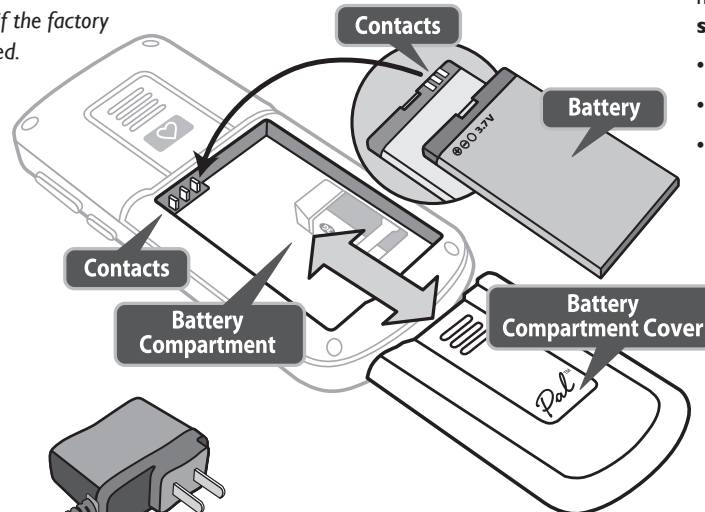

Battery Security

- Use only the factory supplied battery. The use of non-original parts will void the manufacturer's warranty.
- The new battery can achieve the best performance only after two or three complete charging and use cycles.
- The battery may be charged for hundred's of times. However, over time, the power will degrade and performance will degrade. Install a new battery when the idle and talk time are apparently shortened.

Unplug and disconnect the AC Power adapter when not in use. Do not connect the battery to the AC Power adapter for more than a week. **Over-charging will shorten the life of the battery.**

- Do not store the battery with metal.
- Do not bend or open the battery.
- Do not place the battery in water or fire.

SIM Card Installation

SIM card

Your network provider will supply you a SIM card. The SIM card is key for accessing the GSM network.

All information about the network and your calling record will be saved to the SIM card, along with the phonebook list and messages. The SIM card can be transferred to other GSM mobile phones.

Avoid touching the metal areas of the card, and keep away from metallic sources.

WARNING: Do not remove card when the phone is powered ON, or connected to an AC power source.

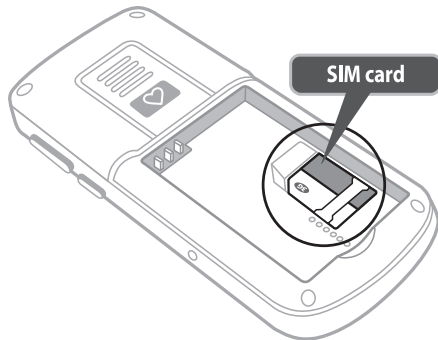

Install/Remove SIM card

Step 1: Power OFF the phone.

Step 2: Remove battery.

Step 3: Insert the SIM card as shown below. Metal face down.

Step 4: Re-install battery. (See page 14 for battery installation instructions.)

Locking SIM card

To avoid illegal use, the phone is protected by a PIN code.

Step 1: Power ON the phone.

Step 2: Select SIM card locking function.

Step 3: Input the appropriate PIN code.

Important: The network provider will supply a standard PIN code. You should choose to change this code to a personal code of your choice.

Note: The default phone password is [1122].

You may also unlock the card by using the PIN code.

The PIN code protection can also be cleared, if errors occur in the process. However, be advised that after this unlocking process, the card is not protected, and unauthorized use is possible.

Important: If the wrong code is inserted continuously for three (3) times, the card will be locked by the network. To correct this error, a PUK code will have to be used.

Connecting to a Network

Connecting to a network

After unlocking the SIM card, the phone will search for the registered network, or other available network. Once connected, the name of the network provider will show in the middle of the LCD. The phone will be in an idle mode.

Important: If phone prompts the message “Emergency call only” on the LCD, it means the phone is out of service area. However, you may still make emergency calls according to the signal strength.

Locking phone

To avoid illegal use, you should choose the lock phone function, and create a personal password.

Once choosing this function, you will be required to enter this password each time you input a PIN code.

Power ON/OFF

Long press the power key to turn **ON** the phone.

If there is a prompt “insert the SIM card,” then **power OFF** the phone and check the SIM card.

Long press the power key to turn **OFF** the phone.

Note: The phone is powered OFF when a “flash” symbol will displays on the LCD.

Phone lock feature

Step 1

Use Arrow key to select **Settings**. Press M1 Memory key to select **OK**.

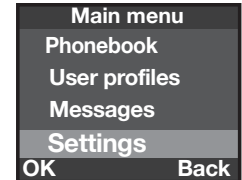

Step 2

Use Arrow key to select **Security setup**.

Press M1 Memory key to select **OK**.

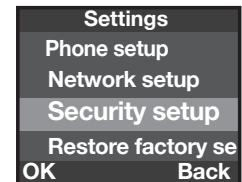

Step 3

Use Arrow key to select **Phone lock**.

Press M1 Memory key to select **ON**.

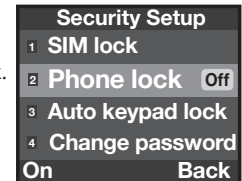

Step 4

Use keypad to enter password.

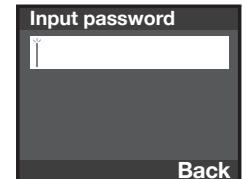

Menu Overview

The Clarity Pal main menu is organized to feature the following options and functions.

- Phonebook
- User Profiles
- Messages
- Settings
- Bluetooth
- Organizer
- Shortcuts
- Accessibility
- Phone calls

Note: Please see additional pages for instructions concerning each menu item listed below.

Main Menu options

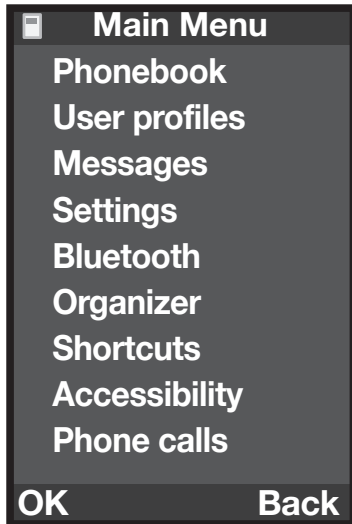

Phonebook

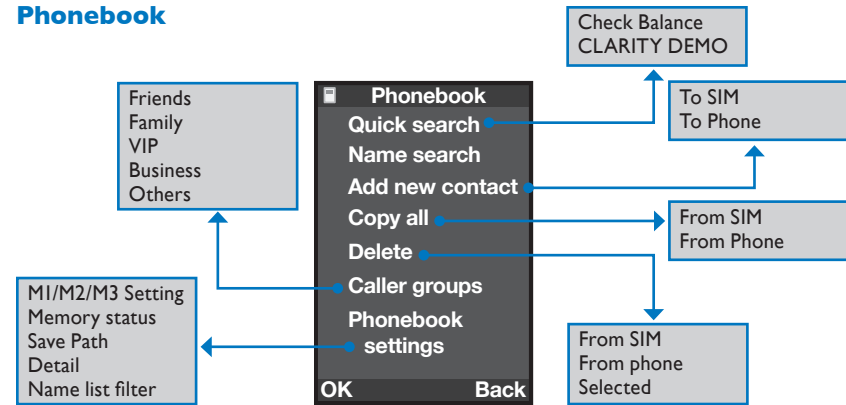

User profiles

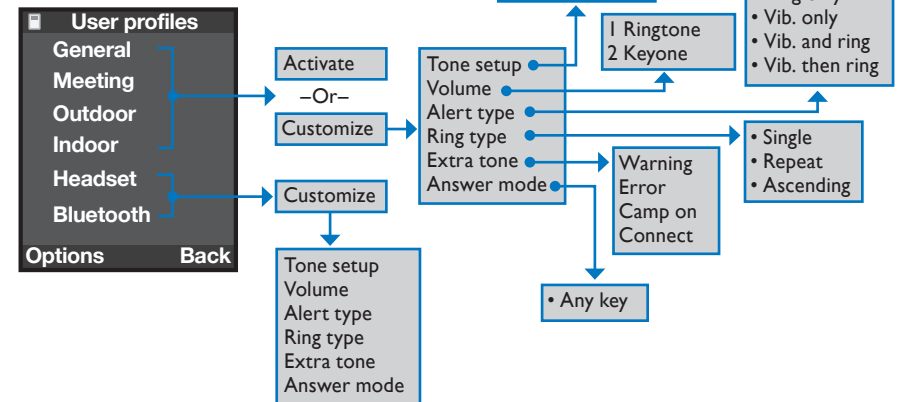

Menu Overview

Messages

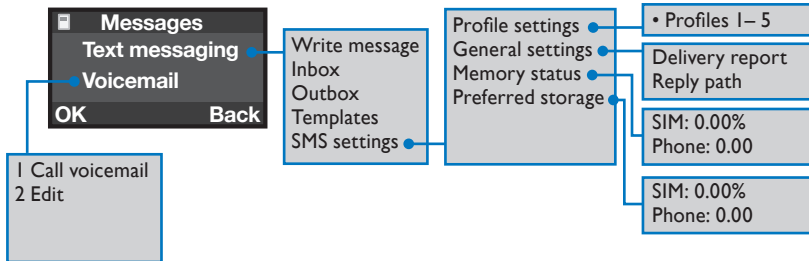

Settings

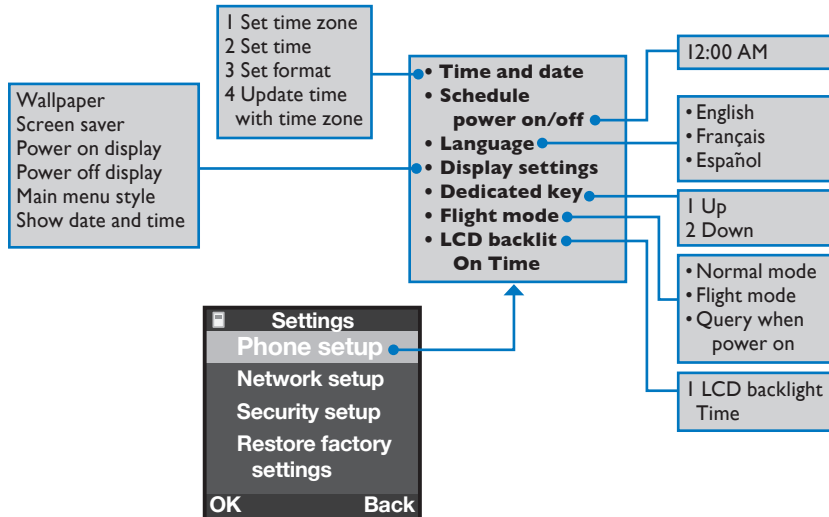

Settings – Network Setup

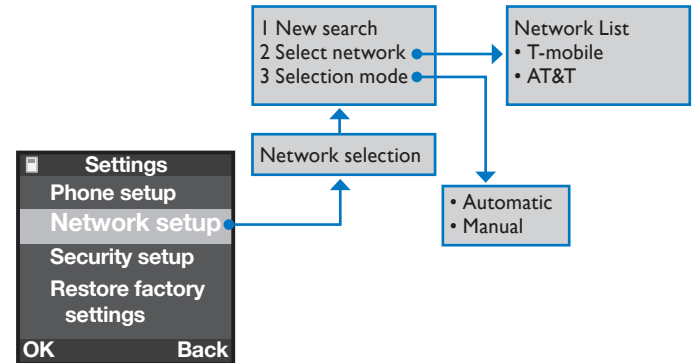

Settings – Security Setup

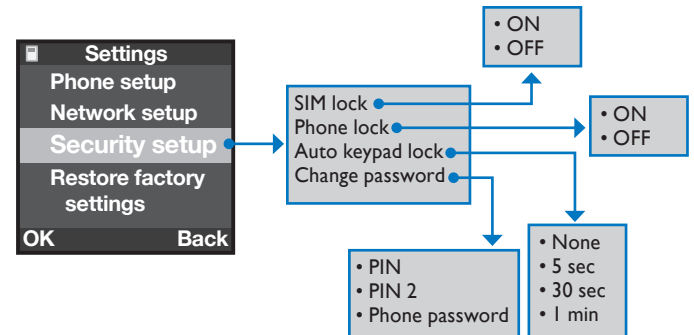

Settings – Restore Factory Settings

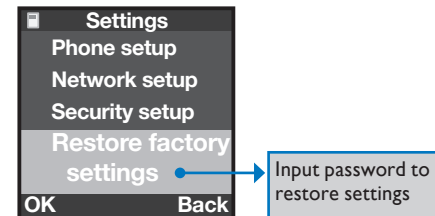

Menu Overview

Bluetooth

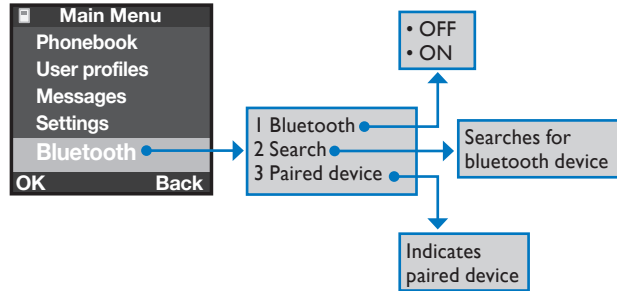

Organizer

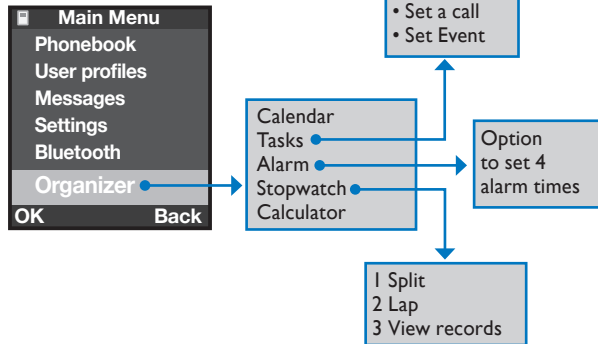

Shortcuts

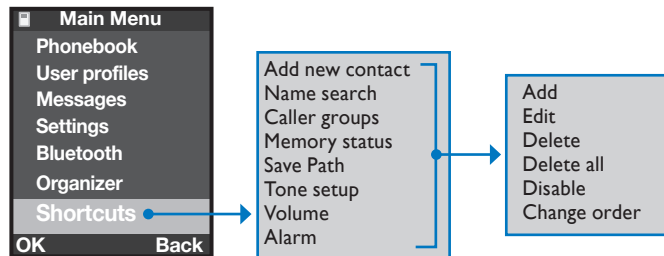

Accessibility

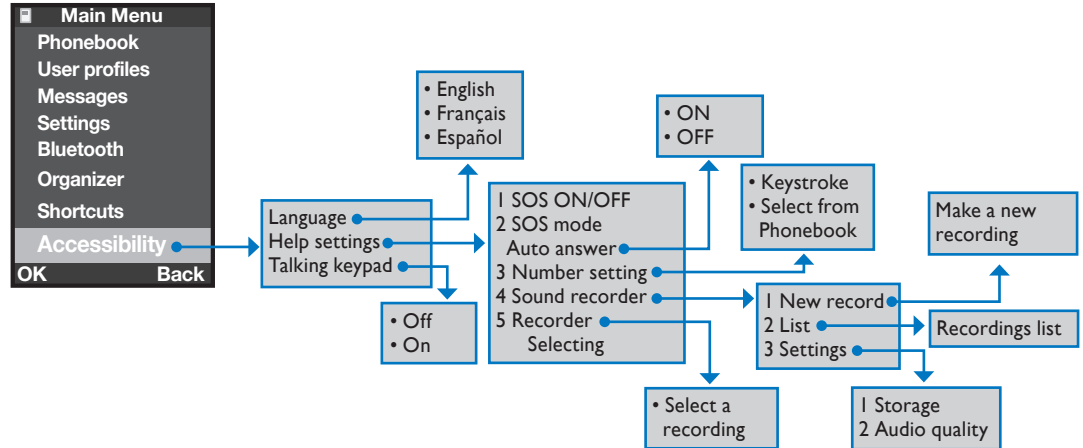

Phone Calls

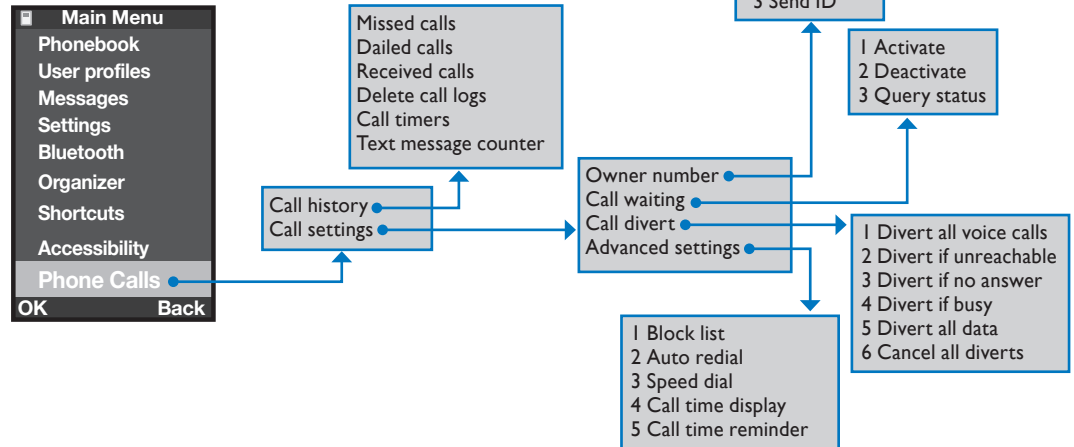

Making a call

The icon on the top left corner of the LCD indicates the signal strength.

Signal strength

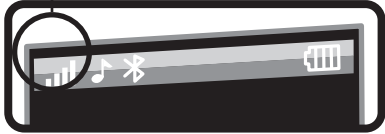

There are three methods to make a call.

- **Phonebook** — Find the number to dial, then **press the dial key**.
- **Call history** — Enter the list of missed calls, received calls or dialed calls, then choose the record, **press the dial key**.
- **Manual** — In idle mode, you can input the number by numeric keys, then **press the dial key**.

Dialing status

Enter the dialing status. The signal strength and other icons will be displayed when dialing. A “blinking” stick indicates the location of the cursor.

Steps for inputting the number:

- Step 1:** Delete the character before the cursor.
- Step 2:** Dial the number by using the dial key.

Step 3: Press * key twice to input “+”, which can be used to make international calls. Press * key three (3) times to input “P”, which can be used for DTMF functions.

Connecting status

After dialing the number, the LCD will display signal strength and battery indications. If the number is not in the phonebook, the number will be displayed — otherwise the name will be displayed.

Calls outside local service area

The simplest method to make a call is to input the number by numeric keys, then press the dial key. If you make a mistake, touch the **M3 key** to **clear the error**.

- To make calls out of your local service area, enter the area code, followed by the phone number, and then press the dial key.
- After dialing the number and pressing the dial key, a “calling” message will display on the LCD.
- **Short Press** the **Power Key** to end or abort the call.

Calls to extension numbers

Some fixed phone numbers do not allow direct access. If so, dial the switchboard number, then the extension number.

Insert “P” between the switchboard number and extension to complete the call.

[Area code] + [switchboard number] + [P] + [extension number] + [dial key]

International calls

Press * key two (2) times to input “+”, then the LCD will display “+” which will allow you to make a call from any country when the country prefix number is known.

Step 1: Input “+”.

Step 2: Input country code

Step 3: Input the complete phone number

Step 4: Press Dial key

Note: Country codes are unchangeable, however, you must remove the “0” from city codes.

[+] + [country code] + [complete phone number] + [dial key]

Calls from a list

All calls you dial and receive will be saved in the phone.

The numbers will be categorized by: “Missed Calls”, “Received Calls”, and “Dialed Calls”.

Check all calls in the phone **call log**.

When the memory is full, old calls will be automatically erased.

Note: You can save a new call to the phonebook.

Emergency calls

If the phone is within the service network, whether using the GSM network, you can make emergency calls. If you have no roaming services in the area, LCD will display “Emergency Calls Only”. As long as you are in the network, you can make Emergency Calls even without a SIM card.

Receiving calls

When there is an incoming call, the ring will sound or the phone will vibrate.

Signal strength and battery indication will display on the LCD while receiving. If the contact number is saved in the phonebook, the contact name will display — otherwise, only the contact number.

Click “Answer” to answer the call, or **click “Refuse”** to reject the call.

Receive a call by pressing the option, or by pressing the “DIAL” (connect) key.

To reject the call, press the **POWER ON/OFF Key**.

Note: If the headset is inserted, you can receive the call with the headset. If auto answer function is **ON**, and the headset is inserted, the call will be **auto-answered after 2 seconds**.

Conversation process

The conversation begins once connected.

LCD display: caller’s photo (if present), number or name, call duration (if this function is open).

Function operation

During the conversation, enter the talking options, press **POWER ON/OFF** key to end the call; or use the numeric dial key. If you make a new call, the current call will remain.

- **Short Press POWER ON/OFF** key: ends the conversation.
- Use the **UP/DOWN navigation key**, or **Volume UP/DOWN button** on left side of phone adjust the volume of the earpiece.
- **Press the MI memory key** to access the menu and enter the call options.

Call options

You can enter call options during a conversation — some functions can only be seen during a conversation.

Note: Other functions, such as call transfer, conference call, call holding, and call waiting require network support. Refer to your network provider for details.

Call options functions:

- **Hold single call:** Pause one of the conversations during a multi-party call.
- **End single call:** End the current call.
- **New call:** After pausing of in-progress calls, you can dial a new call.
- **Phonebook:** Enter the phonebook menu.
- **Message:** Enter the message menu.
- **Sound recorder:** Record the calling details.

- **Mute/Resume:** Open or close the mute mode.
- **DTMF:** Send DTMF signal.

Tone button use during conversations

Provides three (3) tone effects: Soprano, Bass, and Alto.

During conversations, switch these effects by pressing the **TONE** and **BOOST (25dB)** buttons on the right side of the phone.

The **BOOST (25dB)** button increases or recovers the volume.

Auto DTMF

Input a phone number with a “P”, and the phone will enter the DTMF mode automatically.

[letter P] + phone number = DTMF mode

Auto response

After inserting a headset, and setting the auto answer function, the phone will auto answer after two (2) seconds.

FUNCTION MENUS

Rolling searching functions

In idle mode, **press the MI (left) memory key** to enter the menu.

During a conversation, press “options” to enter.

In all main or submenus, you can scroll to the function needed by using **UP/DOWN/LEFT/RIGHT key** (using **UP/DOWN key** to turn pages), and then press the (left) **MI memory key** to enter the function.

Personal shortcuts

Normally, the submenus and the “options” have a **shortcut number** by which you can enter the different functions. Input the shortcut number of the submenu in the list, the relevant option will be displayed.

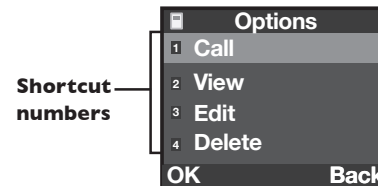
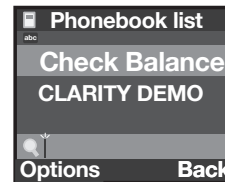
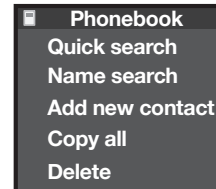

Exit

You can press the **right Memory Key (M3)** to exit from a function. You can **press the OFF** key to return to idle mode.

Phonebook

There are two (2) memory types: SIM card and phone. The number of SIM card entries will depend on the type of card. The phone capacity is 250 entries.

Press the MI memory key to select **MENU**, choose **Phonebook**, and press the MI memory key again (OK).

There are a number of options available such as Quick search, Name search, Add new contact, Copy all, Delete and Caller Groups, and Phonebook settings.

You can choose the following functions within the phonebook:

- **Quick search**
- **Name search:** you can search the linked record by name.
- **Add new contact:** add new record to the SIM card or phone.
- **Copy all**
- **Delete:** choose to delete single records or all records on the SIM or phone. **Note:** to delete all records, you are required to enter the phone’s password.
- **Caller groups:** there are five (5) groups. You are able to set the name, ring-tone, picture, group members.

- **Phonebook settings:** set the phonebook functions as follows: M1/M2/M3 Settings, Memory status, Save Path, Detail, and Name list filter.

Selecting functions under the Phonebook option:

Step 1

Use Arrow key to select **Phonebook**. Press M1 Memory key to select **OK**.

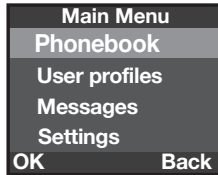

Step 2

Use arrow key to scroll/select **Caller groups**. Press M1 Memory key to select **OK**.

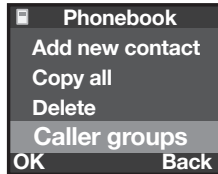

Step 3

Select the type of caller group.

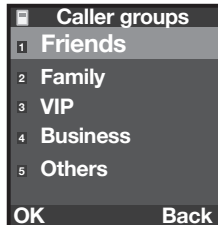

User profiles

The phone includes six basic profile modes: general, meeting, outdoor, indoor, headset, and bluetooth.

In each profile mode you may choose to select the basic settings (**Activate**) or personal settings (**Customize**).

- **General mode:** Same setting options as General mode.
- **Meeting:** Same setting options as General mode.
- **Outdoor:** Same setting options as General mode.
- **Indoor:** Same setting options as General mode.
- **Headset:** Headset mode will be activated when a headset is connected.
- **Bluetooth:** The phone will enter into Bluetooth mode when the Bluetooth opens.

Note: On standby screen, Long press “#” to open/close mute mode.

Customizable features

There are (5) customizable options for each profile mode.

Tone setup: set incoming call ring, alarm clock ring, power on/off ring, message ring and key tone.

Volume: 1–7 volume levels for ring and key tone.

Ring type: ring, vibration, ring/vibration, ring after vibration.

Extra tone: warning, error, network-connecting, call-through.

Answer mode: any key answer, or auto answer.

Step 1

Use Arrow key to select **User profiles**. Press M1 Memory key to select **OK**.

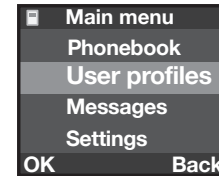

Step 2

Use Arrow key to select **General**. Press M1 Memory key to select **Options**.

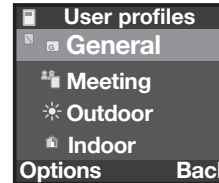

Step 3

Use Arrow key to select **Customize**. Press M1 Memory key to select **OK**.

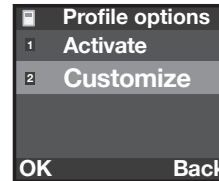

Step 4

Use Arrow key to select **Tone setup**. Press M1 Memory key to select **OK**.

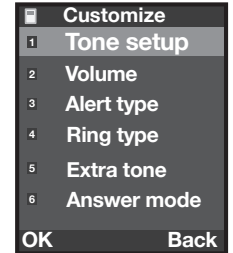

Step 5

Use Arrow key to select **Incoming call**. Press M1 Memory key to select **OK**.

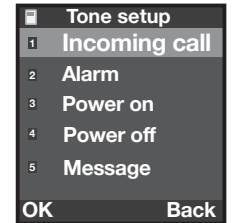

Step 6

Use Arrow key to select a **Ring style** of your choice. Press M1 Memory key to select **OK**.



Writing and sending messages

Step 1

Use Arrow key to scroll to **Messages**.

Press MI Memory key to select **OK**.

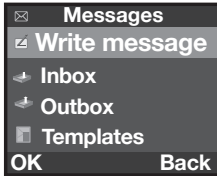

Use Arrow key to select **Write Message**.

Press MI Memory key to select **OK**.

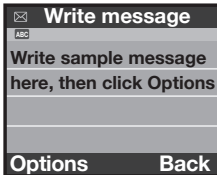

Step 2

Use keypad to write message.

Press MI Memory key to select **Options**.

Use Arrow key to select **Done**.

Press MI Memory key to select **OK**.

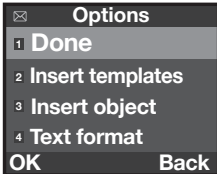

Step 3

Use Arrow key to select **Send only**.

Press MI Memory key to select **OK**.

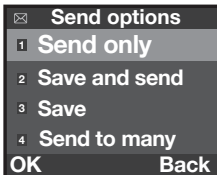

Step 4

Enter the number manually, or Press MI Memory key to select **Search**.

Step 5

In phonebook list type the contact's name in the search field and Press MI Memory Key to select **OK**.

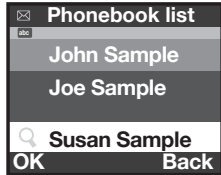

Step 6

When contact's number appears in screen, Press MI Memory Key to select **OK**.



Step 7

Message sending prompt appears on screen.



Step 8

Confirmation of message sent prompt appears on screen.

Write a SMS message

Press **"#"** key or the **MI Memory key** to switch the input methods: ENGLISH (ABC)(abc); SPANISH/spanish; FRENCH/french.

Six options to Write Message function:

- Done
- Insert templates
- Insert object
- Text format
- Insert contact number
- Insert contact name

Note: After editing the message, you can send, save and send, save, send to multiple contacts, or send to a group.

Send: send it to the corresponding person.

Save and send: save the message to outbox, and then send it out.

Save: save the message to the outbox.

Send to many: send the message to more than one contact.

Send to group: send the message to all members of a group.

After sending the message, the phone will return to the SMS menu. If message reporting has been set, you will receive a successful delivery report. Refer to the SMS setting, for instructions in setting the message reporting function.

Note: Refer to **"input methods"** for details.

Inbox

Check the messages received in the inbox, and perform the following functions: reply, delete and delete all, edit and edit all, forward, copy, and copy all, move, move all, and move to SIM or phone memory, use the number (dial out or save), use the connection and (connect to website in SMS directly).

If the inbox has no message, a **"empty"** prompt will appear.

Outbox

Check the messages saved in the outbox already sent, or unsent and reply, delete, edit, forward, copy to phone/SIM, move to phone/SIM, delete all, copy all, move all, use the number, and use USSD.

Templates

You can set some common templates for convenience. Templates can be modified or deleted. Or, you may choose to create a new template.

Message setting

Basic settings before using the message function:

Profile setting: Select an appropriate profile name. **Note:** After entering a single format, you can set the file name, SMS center number, validity period and sending format.

General setting: set the message report options: **Delivery report** and **Reply path** (On/Off).

SMS settings

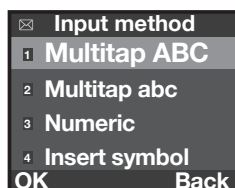
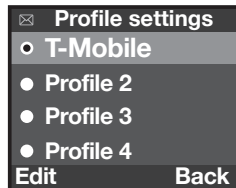
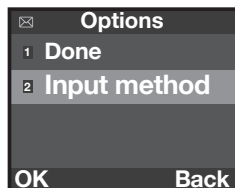
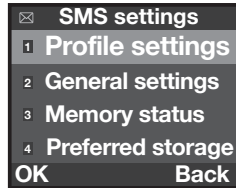
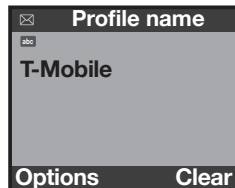
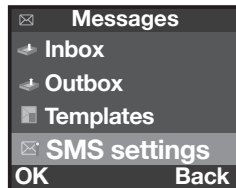
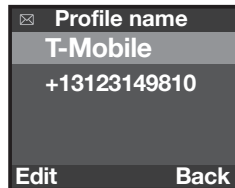
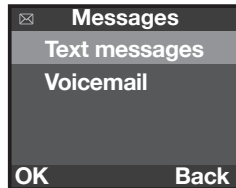
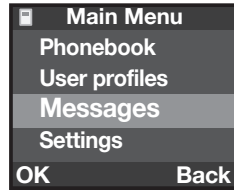

Memory status: set the storage options for the phone and SIM card.

Preferred storage: choose SIM card or phone.

Write a MMS message

Send to many: input the contact information, which may include a single or multiple phone numbers. (maximum 20).

Step 1: Press left MI Memory key to select “edit”. Add the number or e-mail address.

Step 2: Choose “add number.”

Note: If the editing area is blank, press “search” to view phonebook numbers, then press “OK” to add.

You can edit or delete the phone number of the contact if necessary. If you select “delete all” — all numbers and e-mail addresses for that contact are deleted.

Note: After writing a new MMS, you may choose to send, save/send, save to draft, or edit message settings by choosing “sending options,” or simply exit.

Inbox

Display all MMS messages received. You can check, reply, reply to all, forward, delete, delete all, view details and use the details.

Outbox

Display all MMS messages sent.

You can check MMS details, resend, edit, delete, delete all, view details and use the details.

Draft box

All MMS messages written, but not sent. You can check MMS details, send, edit, delete, delete all, view details and use the details.

Templates

Template formats saved.

Voice mail box

Voice mails received are saved in your network. Dial the number of the mail box to listen to voice mail.

Voice mail functions:

- **Connect to voice mail:** dial voice mail number and listen to message.
- **Edit:** add or edit the name and number of the mail box.

Settings

Options are set in the phone, including screen adjustment, phone setting, call setting, network setting, security setting, and restore factory defaults.

Operations

Phone setup

Time and date

- **Set time zone:** Set home city
- **Set Time and Date**
- **Set format:** Time /Date MM/DD/YYYY
- **Update time with time zone:** Select Off/On

Schedule power ON/OFF: Four (4) times available.

Language: English/Spanish/French

Display settings

- **Wallpaper:** Choose the wallpaper for the idle mode (7 options).
- **Screen saver:** choose picture, and the wait time.

- **Power on display:** Choose flash when power ON (7 options).
- **Power off display:** choose flash when power OFF (7 options).
- **Main menu style:** choose single page or list.
- **Show Date/time:** choose whether to display date and time in idle mode.

Dedicated key

- Set the functions of the “Navigation” keys in idle mode (Select UP/DOWN).

Flight mode

- Normal mode, flight mode, and Query when powering ON.

LCD Backlight ON Time

- Illumination level and time of LCD backlight.

Operations

Phone Setup (Time and date — Schedule power on/off — Language)

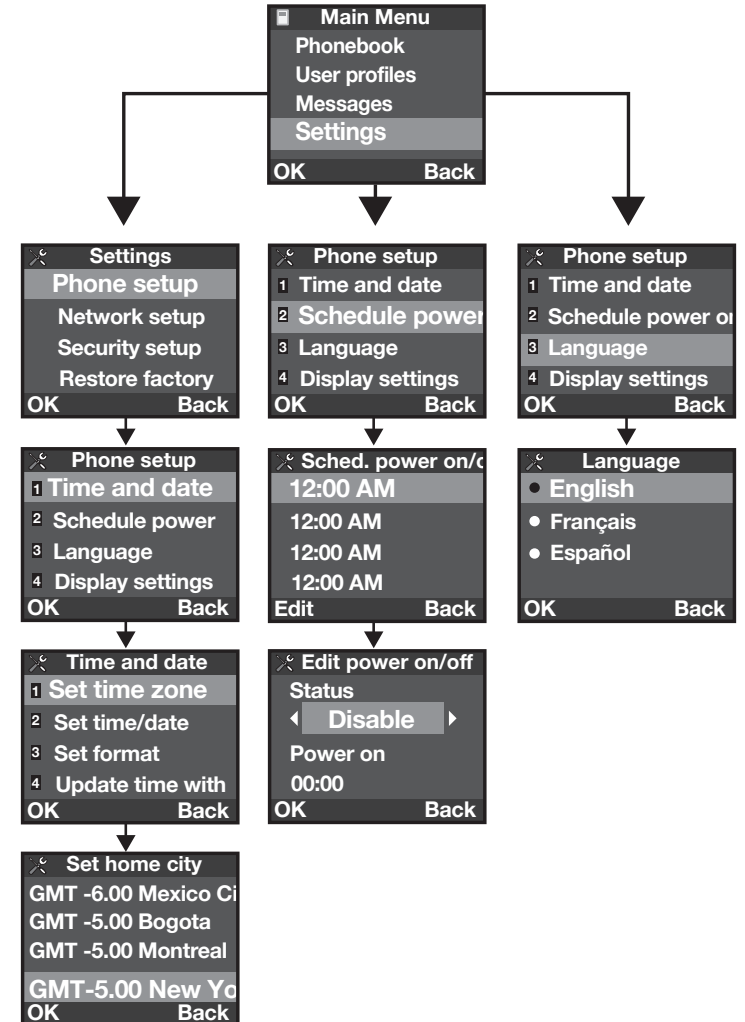

Network setting

• Network selection

- New search
- Select network (Automatic)
- Selection mode (Automatic/Manual)

Security settings

• SIM lock

Use PIN code (code is changeable) to lock the SIM card. Security options for the phone and SIM card can be set to prevent unauthorized use.

PIN code can be toggled ON/OFF. If the code is OFF, the phone will ask for it upon powering-on.

Note: SIM lock must be enabled before changing PIN. If you input the PIN code in error more than three (3) times, the SIM card will lock. A PUK code will be required to unlock the card. The PIN and PUK code may be provided to you with the SIM card. If not, contact your network provider.

The default code is [1234].

Change it to a personal code as soon as possible.

• Phone lock

You may choose to lock the phone to avoid unauthorized use. However, this requires an input of the personal password each time the phone is powered ON.

Note: The default phone password is [1122]. Change it to a personal password as soon as possible.

• Auto Keypad lock

Set the waiting time for locking keypad. After setting, the keypad will lock automatically, if not used within the appointed time. **Press the right “M3” memory key, then press the “#” key.**

• Change password

Change the password, including PIN, PIN2 code, and mobile lock password.

• Changing PIN code

Select “Settings. Select “security setup.” Select “Change password.” Select “PIN.” Enter old PIN number. Then create a new PIN number. Enter the new PIN number again to confirm.

Network and Security settings

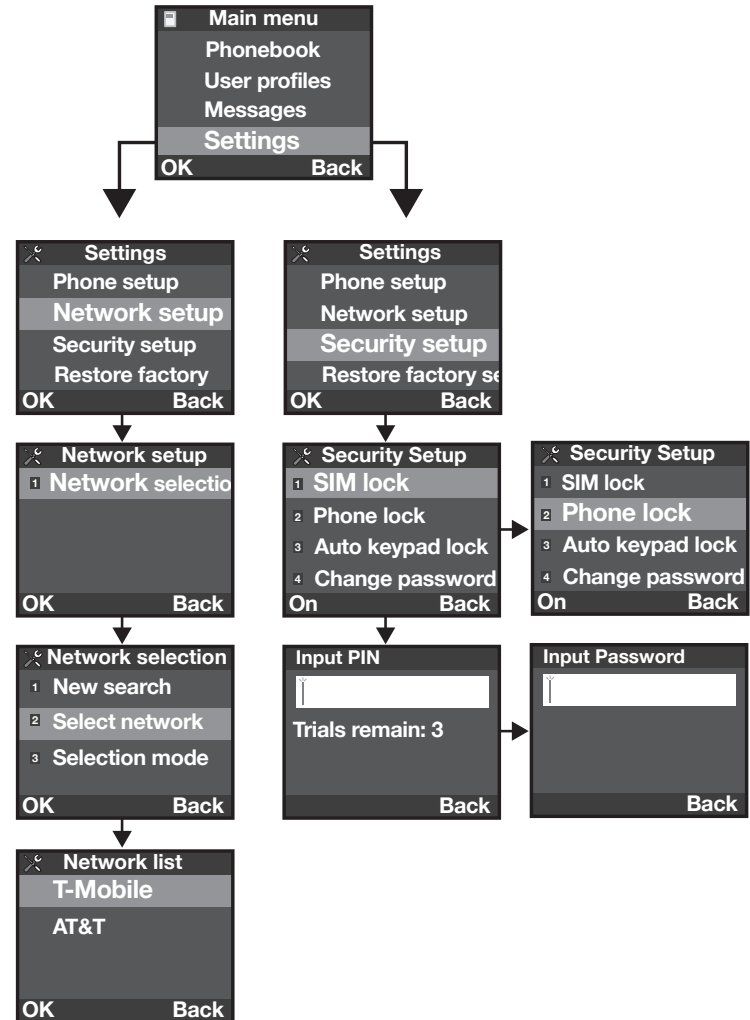

Restore factory settings

Input the password of the mobile lock. The factory default may also be reset.

Note: The default phone password is [1122]. Change it to a personal password as soon as possible.

Bluetooth

The phone can be connected with Bluetooth which is in range of 10m (32 feet).

The wireless connection of Bluetooth may be interfered with by obstacles, or electronic equipment.

Bluetooth menu settings

- **Bluetooth activation: ON/OFF**

- **Search**

Activate Bluetooth, and the headset before entering the menu, then begin to search for the audio device. You will be asked to input the password of the device. After pairing, you may use Bluetooth for talking or MP3.

Note: the password is different for each audio device. Refer to your audio device manual for specific instructions.

- **Paired device**

The name of audio device will be displayed after pairing.

Organizer

- **Calendar**

You can check or edit the memo of the appointed date.

Functions:

View: check or edit the memo of the date. Refer to memo for details.

View all: all schedules are visible.

Add event: add new schedule.

Delete event: delete all/delete past or certain time schedule.

Jump to date: skip to the appointed date to check or edit the memo.

Go to weekly view: display calendar by week or month.

- **Tasks**

Add important events, reminders, and phone-calls, etc.

- **Alarm**

Set important reminder alerts.

- **Stopwatch**

There are two timing functions in the menu:

Split and **Lap** timing.

Split timing: Maximum 20 split timing for each record.

Lap timing: Maximum 20 lap timing for each record.

View records: enter to check the timing record. If there is no record, the LCD will display a prompt **“empty.”**

- **Calculator**

Operations:

Input the first number: when “0” is displayed on LCD, input the first number.

Input the counting symbol followed by the second number:

Press [M + / +]

Press [M - / -]

Press [MC/ *]

Press [=] equal mark to show result.

Keep calculating: use the result to continue calculating.

Clear: press right “M3” key. The content cleared is determined by inputting status. If result is already determined, then “0” is displayed on LCD. If numbers or symbols are input, then only the current number or symbol is cleared.

Exit: press “Back” to exit. If there is no soft “Back” key on LCD, then press “Clear” to exit one-by-one.

Shortcuts

There are nine (8) shortcut menus.

The following functions are available: **Add, Edit, Delete, Delete all, Disable, and Change order.**

The following standard menus may be added as a shortcut menu:

Add new contact, Name search, Caller groups, Memory status, Save Path, Tone setup, Volume, and Alarm.

Accessibility

Options:

Access Language, Help Settings and Talking keypad.

- **Language**

Select English, Français, or Español.

- **Help Settings**

- **SOS:** Select On or Off

- **SOS mode Auto Answer:** Select On or Off

- **Number setting:**

Add phone numbers manually or from the Phonebook contacts.

- **Sound recorder:**

Record your message.

- **Recorder Selecting**

If there are no entries, “Empty” will display in the menu.

Record options:

1 – New Record

Make a new record. During record, press the left “M1” key to pause or continue. Press the right “M3” key to stop. Next, rename the file and press the left “M1” key to save.

2 – List

In recording files list, if there is no entry, the LCD will display “empty.”

Select: select current record as SOS emergency alarm ring. **Note:** If there is no record, it will play blank.

Play: play the chosen record.

Rename: rename the file.

Delete: delete the file.

Delete all: delete all files.

Send: send the record to MMS or Bluetooth.

3 – Settings

Set the storage option in the phone. Select Audio quality.

Note: If there is an incoming call during record, the record will stop automatically, and the recorded content will be saved.

• Talking keypad

Select either OFF or ON.

Phone Calls

Select either “**Call history**” or “**Call settings**”.

Call history menu:

- Missed Calls
- Dialed calls
- Received calls
- Delete call logs
- Call timers
- Text message counter

Call settings menu:

- Owner number
- Call waiting
- Call divert
- Advanced settings

The phone can store missed, dialed, and received calls – maximum of 20 per group.

Call History Options:

Missed calls: check list of missed calls.

Dialed calls: check list of dialed calls.

Received calls: check list of received calls.

Note: Choose one record to check details, including date, time, number, call time, and call duration.

Delete call logs: All call log lists may be deleted as a group, or deleted individually.

Call timers: There are four submenus of the “call timers” as follows: Last call, Dialed calls, Received calls, and Reset all.

Text message counter:

Sent: total number of messages sent.

Received: total number of messages received. **Note:** Clear the list by pressing left “M1” key.

Call settings options:

Owner number: Options are, “Default”, “Hide ID”, and “Send ID”.

Call waiting: Activate, Deactivate or Query status.

Call divert options:

Divert all voice calls: call divert in all conditions.

Divert if unreachable: call divert when number cannot be connected.

Divert if no answer: call divert when there is no answer.

Divert if busy: call divert when line is busy.

Divert all data: call divert to a new number.

Cancel all diverts: cancel all call diverts.

Advanced settings:

Block list: set calls to not answer as “black list.” (20 numbers maximum.)

Auto redial: set this function to automatically redial an unconnected call.

Speed dial: set speed dial. In idle mode, **long press** the relevant numeric key to make the call.

Call time display: Enter IP number and press OK to confirm settings, then cancel or edit.

Call time reminder: options are OFF, Single, and Periodic.

Input methods

Input by English

The following are definitions of the keypad in **English-input mode**.

(Includes ABC and abc.)

Input by keypad

Operations of English input:

- Each key can be used to input several characters.
- Quick click the key until the letter you desire appears.
- Press **(*) key** to input English symbol.
- Press **(#) key** to switch input methods.
- Press **(0) key** to input blank.
- Press **Right (M1)** key to clear one character.
- **Long-press Right (M3)** key to clear all characters.

Input by English

The following are definitions of the keypad in **English-input mode**.

(Includes ABC and abc.)

Key name	Corresponding character or function	Note
Number 0 key	Number 0 or blank	
Number 1 key	Symbol	
Number 2 key	ABC, abc, number 2	
Number 3 key	DEF, def, number 3	
Number 4 key	GHI, ghi, number 4	
Number 5 key	JKL, jkl, number 5	
Number 6 key	MNO, mno, number 6	
Number 7 key	PQRS, pqrs, number 7	
Number 8 key	TUV, tuv, number 8	
Number 9 key	WXYZ, wxyz, number 9	
* key	Get symbol list	
# key	Switch input method	
Up key	Move cursor Up/Forward	
Down key	Move cursor Down/Forward	
Left key	Scroll to Left	
Right key	Scroll to Right	
Right function key	Return or clear	
Power key	Exit to idle mode	

Input by number

The definition of keypad under number input mode.

Input by keypad

Operations of number input method:

- Press **0-9** key to input the number.
- Press (**#**)key to switch the input method.
- Press **Right (M3)** key to clear one character. Long-press **Right (M3)** key to clear all characters.

Input by number

The definition of keypad under number input mode.

Key name	Corresponding character or function
Number 1 key	Number 0 or blank
Number 2 key	Symbol
Number 3 key	ABC, abc, number 2
Number 4 key	DEF, def, number 3
Number 5 key	GHI, ghi, number 4
Number 6 key	JKL, jkl, number 5
Number 7 key	MNO, mno, number 6
Number 8 key	PQRS, pqrs, number 7
Number 9 key	TUV, tuv, number 8
Number 0 key	WXYZ, wxyz, number 9
# key	Switch input method
Up key	Move cursor Up/Forward
Down key	Move cursor Down/Forward
Left key	Scroll to Left
Right key	Scroll to Right
Left function key	Options
Right function key	Return or clear
Power key	Exit to idle mode

Troubleshooting

Problem: SIM card error.

Reason: SIM damaged.

Reason: SIM card not setup correctly.

Reason: SIM card dirty.

Solutions:

- Contact the network provider.
- Check the SIM card settings, and clean the card.

Problem: Weak, interrupted, or no signal.

Reason: Signal strength can be affected by obstructions such as high buildings, or confinements such as basements and subways.

Solution: Move to a more open area.

Problem: Phone will not Power ON.

Reason: Battery uncharged, used-up, or defective.

Solutions:

- Charge battery.
- Replace battery.

Problem: Phone will not connect a call.

Reason: Barring function is activated.

Solution: Cancel barring dialing function.

Contact Information



Clarity, a Division of Plantronics, Inc.
6131 Preservation Drive, Chattanooga, TN 37416

Telephone: 800-426-3738 Fax: 800-325-8871

E-mail: claritycs@plantronics.com

Website: ClarityProducts.com

Problem: No connection to network.

Reason: SIM is invalid or defective.

Reason: Out of GSM service area.

Reason: Weak, interrupted, or no signal.

Solutions:

- Contact the network provider.
- Move the phone into the GSM service area.
- Try connecting again in a better signal environment.

Problem: Phone will not charge.

Reason: Voltage is unsuitable.

Reason: Non-standard charger.

Reason: Not connected.

Solutions:

- Use the recommended voltage.
- Use the factory supplied charger.
- Check connections at AC power outlet, and at the phone.