

PhoneMax[®]

Installation Guide & User Manual

Model TEL 030

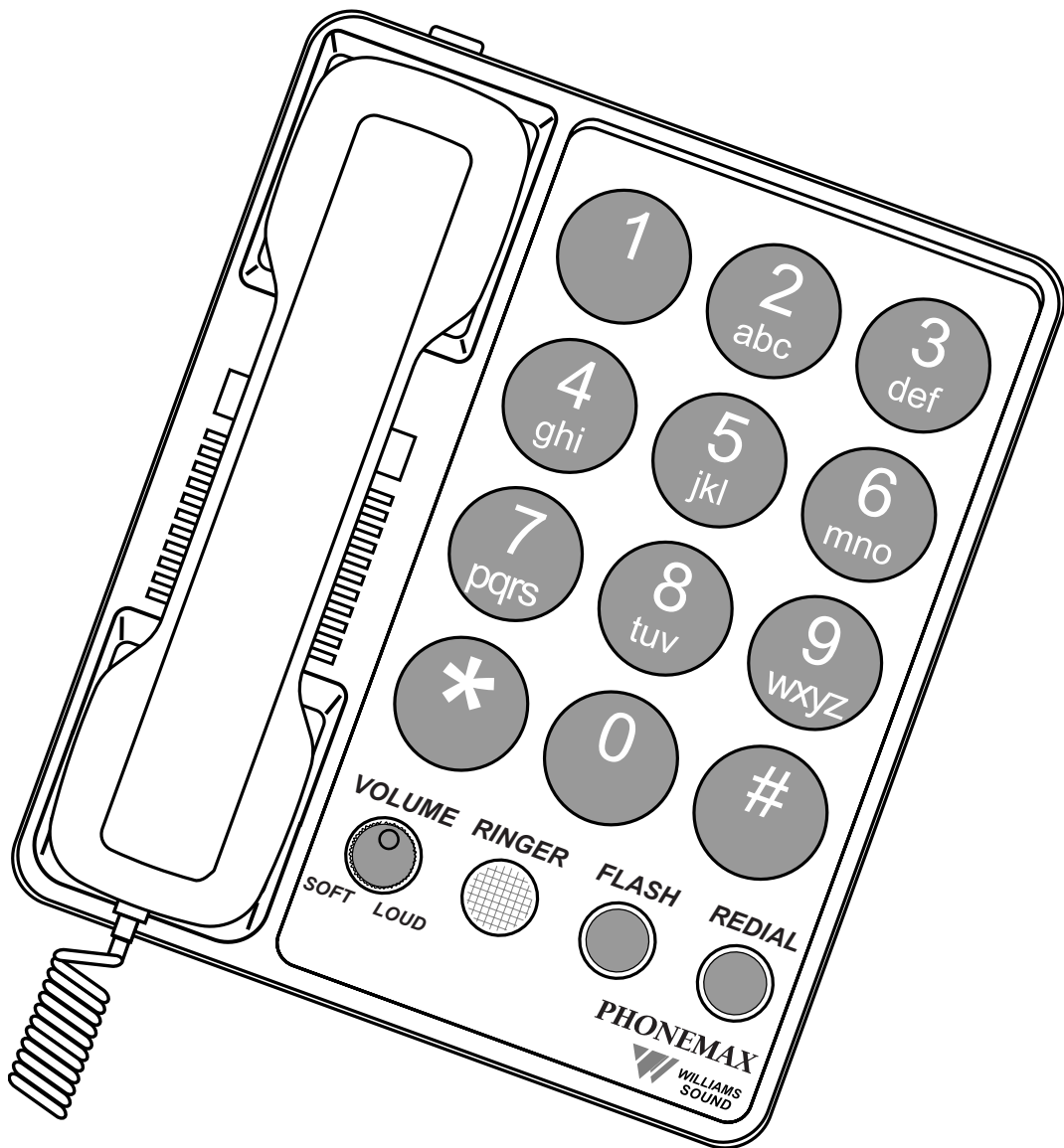

Important Safety Information

Statements in this manual preceded by the following words are of special significance.

WARNING! Means there is the possibility of personal injury to yourself or others.

Other information of particular importance has been placed in italic type like this.

WARNING!

The PhoneMax is capable of amplifying sounds to a very loud volume. Instruct all potential users in its proper operation. Do not let children play with the Phonemax. When the volume control is set to SOFT, the Phonemax functions as a normal telephone.

WARNING!

This telephone can produce very high (loud) sound levels. Always adjust the volume control to the minimum setting after using the phone and alert other users that hearing damage can potentially result from misuse.

WARNING!

This product can be hazardous if immersed in water. To avoid the possibility of electrical shock, do not use it while in the bathtub or shower, or when you are wet. If you accidentally drop it into water, do not retrieve it until you have first unplugged the line cord from the modular wall jack. Do not plug the telephone back in until it has dried thoroughly.

Avoid using the telephone during electrical storms in your immediate area. Urgent calls should be brief. Even though your telephone company may be using protective measures to limit electrical surges from entering your home, absolute protection from lightning is impossible.

If you suspect a gas leak, report it immediately. But use a telephone away from the affected area. The telephone's electrical contacts could create a tiny spark. While unlikely, it is possible this spark could ignite heavy concentrations of gas.

Table Of Contents

PhoneMax Amplified Telephone, Model TEL 030

Contents	Page
Safety Information	2
Introduction	4
Components	4
Features & Functions	4
Installation Steps	6
Table/Desk Installation	7
Wall Plate Installation	7
Bare Wall Installation	9
PhoneMax Operation	10
Using The Volume Control	10
Making A Call	10
Answering A Call	10
Flash And Redial Buttons	10
Using The PhoneMax With A Hearing Aid	10
In Case Of Difficulty	12
Warranty	13
Specifications	14
FCC Notices	15

Introduction

Congratulations on the purchase of your PhoneMax® Amplified Telephone, Model TEL 030. This state-of-the-art Williams Sound product is designed and built with premium quality parts for your assurance of reliability.

The PhoneMax® is designed to improve the intelligibility of the sound signal by emphasizing higher frequency speech sounds. The PhoneMax functions as either an amplified telephone or as a normal telephone for users who don't need amplification.

We suggest you read this user manual carefully to become familiar with the Phonemax's features and their function. The manual explains how to install, use, and care for your new Phonemax.

Components

The following items are included with the PhoneMax:

- Handset
- Coiled handset cord
- Long wall cord
- Short wall cord
- Plastic base
- Wall mount bracket
- User Manual

Features & Functions

Volume Control	Increases sound volume.
Ring Indicator	Flashes when PhoneMax rings.
Flash Button	Used to access special services such as call waiting, conference calling, and PABX functions
Redial Button	Redials last number dialed.
Pulse/Tone Switch	Selects Pulse (rotary phone systems) or Touch-Tone Dialing.

Fig. 1: PhoneMax Features & Functions

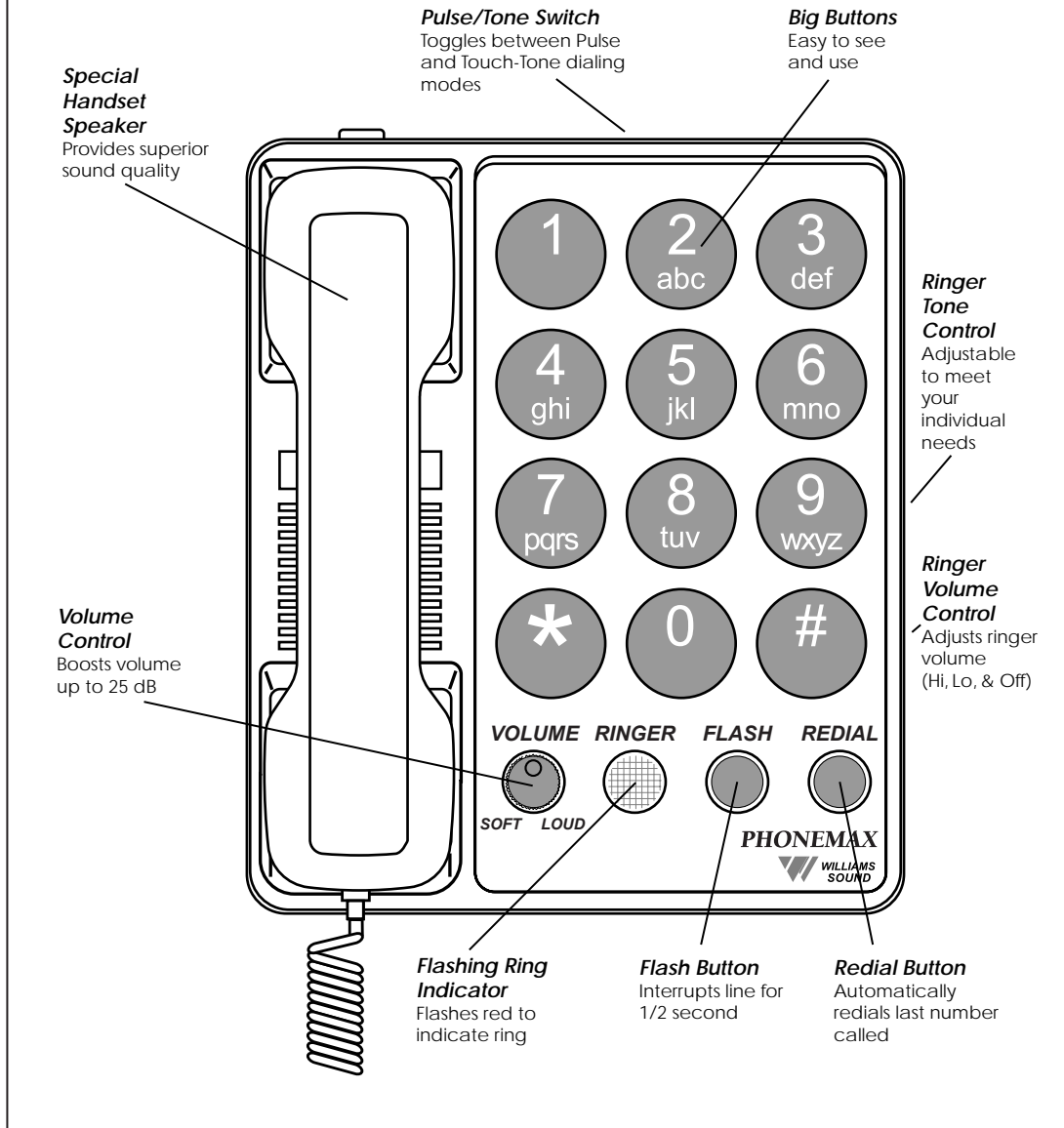

Ringer Volume

Adjusts Ringer volume level.

Ringer Tone Control

Adjusts Ringer tone.

Installation Steps

- Step 1:** Make sure you have a telephone jack within 6 feet of the place you've chosen to install the PhoneMax. If you have an older 4-prong jack, you'll need a modular jack adapter. These adapters are available from electronic, phone, and other retail stores.
- Step 2:** Place the Pulse/Tone Switch, located on the side of the phone, in either Tone or Pulse (Rotary Dial Pulse). *Make sure you choose the correct dialing mode. Tone dialing will not work if you have only dial pulse (rotary) service.*

Fig. 2: Pulse/Tone Switch

Pulse / Tone Switch

Switches between touch-tone and rotary dial modes.

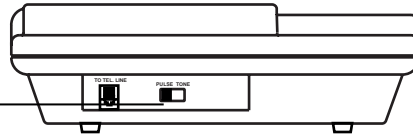

- Step 3:** Set Ringer Volume and Tone Controls to desired level. *(see Fig.3)*

Fig. 3: Ringer Controls

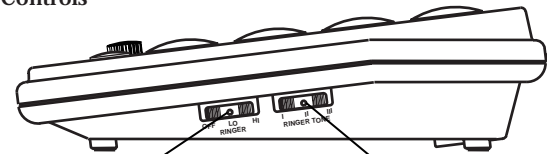

Ringer Volume Control

Adjusts ringer volume (Hi, Lo, Off)

Ringer Tone Control

Adjusts ringer pitch (I, II, III)

- Step 4:** Plug the coiled handset cord into the handset. Plug the other end into the telephone base. *(see Fig. 4)*

Fig. 4: Handset Connection

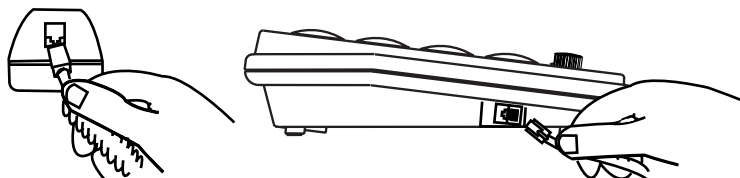

Step 5: Perform either Table/Desk installation or Wall installation as outlined on the following pages.

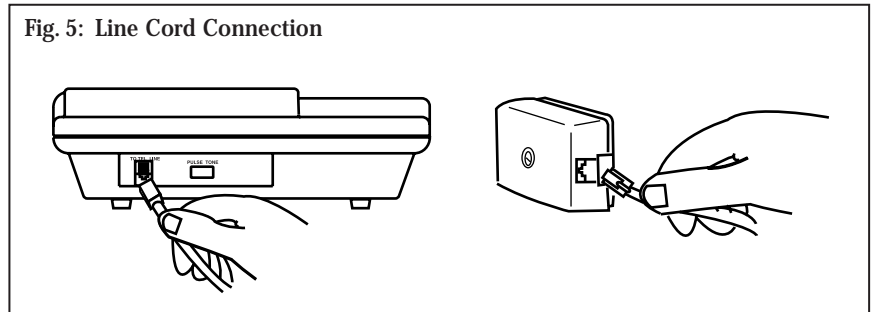

For Table/Desk Installations

- Step 1:** Plug the long line cord into the jack on the back of the telephone base. (see Fig. 5)
- Step 2:** Plug the other end of the line cord into a modular baseboard jack. Make sure both ends snap into place firmly. (see Fig. 5)
- Step 3:** Lift the handset and check for dial tone. If you don't hear a dial tone, see *In Case Of Difficulty*, page 12.
- Note:** To disconnect, squeeze the clip on the plug and pull it out from the jack.

For Wall Plate Installations

If you prefer, the PhoneMax can also be mounted on a studed wall phone plate. If you don't have a phone plate installed, talk to your phone company or local phone products store.

- Step 1:** Clip the plastic wall mounting bracket (included) into bottom of the PhoneMax base unit. (see Fig. 7) Make sure the tabs snap in securely. This will make the base unit level with the wall.
- Step 2:** Rotate the handset hanger found in the handset cradle to prevent the handset from falling. (see Fig. 6)

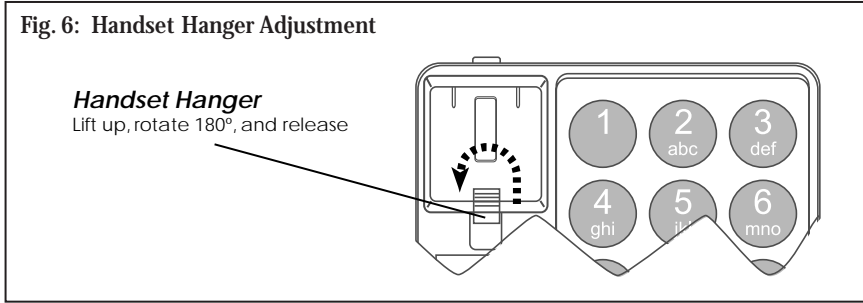

Step 3: Plug the short line cord into the jack on the top of the telephone and thread the line through the channel to the cavity on the back of the base unit.

Step 4: Hold the telephone next to the wall-phone jack and plug the line cord into the jack, leaving any slack in the base unit cavity. Then push the phone against the mounting studs so the studs are hooked into the upper and lower keyhole slots of the phone. Slide the phone down until it snaps into place. (see Fig. 7)

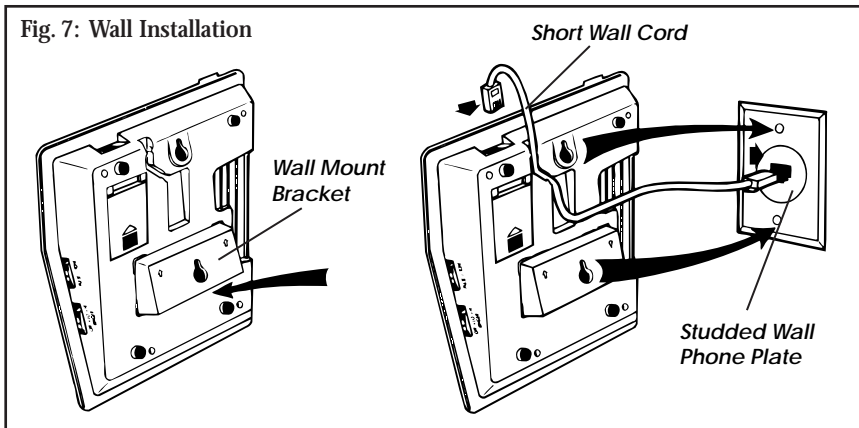

Step 5: Check for a dial tone. If you can't hear a dial tone, see *In Case Of Difficulty*, page 12.

Note: To remove a wall-mounted telephone, slide the phone up and pull it slightly away from the wall. Disconnect the line cord by squeezing the clip on the modular plug and pulling it from the jack.

Bare Wall Installation

Even if you don't have a studded wall phone plate, you can still mount the PhoneMax on any wall surface within six feet of a standard modular jack. To mount the phone farther from the jack you'll need a longer line cord or a telephone extension cord.

- Step 1:** Measure and mark the wall for mounting screws. Mark two points 4.0 inches apart for upper and lower mounting screws. The lower mark should be 48–52 inches from the floor. Use a level to make sure the marks are aligned vertically.
 - Step 2:** Install the mounting screws (not included). Use wood screws for stud mounting, anchor screws for hollow wall mounting. Drive the screws almost completely in, leaving a $\frac{1}{8}$ (0.125) inch space between the wall surface and the bottom of the screw head (about the thickness of two stacked pennies).
 - Step 3:** Rotate the handset hanger to prevent the handset from falling. (*see Fig. 6*)
 - Step 4:** Mount the Phonemax. Hang the telephone on the mounting screws and push down gently until it snaps into place
 - Step 5:** Connect the line cord to the jack on the top of the phone. Plug the other end of the line cord into a modular wall jack. Make sure it snaps firmly into place.
 - Step 6:** Check for the dial tone.
If you can't hear a dial tone, see *In Case Of Difficulty, page 12*.
- Note:** To disconnect the telephone, squeeze the clip on the modular plug and pull it out of the jack.

PhoneMax® Operation

Using The Volume Control

Turn the volume control knob clockwise to increase volume, counter-clockwise to decrease volume.

Making A Call

Step 1: Lift the handset and check the Volume Control setting.

Step 2: When you hear a dial tone, dial the number and use as a regular phone. Adjust the volume control for best understanding of the remote party.

Answering A Call

Step 1: Check the Volume Control setting, lift the handset.

Step 2: Adjust the Volume control to a comfortable setting.

Using Flash And Redial Buttons

Flash Button

The Flash Button produces a .6 second disconnect, useful when picking up an incoming call if your line is equipped with Call Waiting, or when adding another party for three-way calling.

Redial Button

The Redial Button redials the last number dialed.

Using the PhoneMax With A Hearing Aid

The handset can be used directly with hearing aids equipped with a telecoil (T-coil). Move your hearing aid T-switch to the "T" position and hold the handset close to your hearing aid. The volume can be adjusted with the PhoneMax volume control.

WARNING!

The PhoneMax is capable of amplifying sounds to a very loud volume. Always set the VOLUME CONTROL to the SOFT setting before using the phone. Instruct all potential users in its proper operation. Do not let children play with the PhoneMax.

In Case Of Difficulty

Can answer calls but cannot make them

The pulse/tone switch is set in the wrong position. Change it to pulse mode.

No dial tone when you pick-up handset

There are a number of potential causes to this problem:

1. Cords on handset or phone are not plugged into jacks. Make sure connectors are plugged in securely.
2. The cord could be damaged. If so, replace the cord.
3. The wall jack could be improperly wired. Check the wall jack for proper wiring.
4. Your phone line could be out of order. Contact your local phone company.

Can make calls, but phone doesn't ring for incoming calls.

There are a number of potential causes to this problem:

1. The handset may not be placed properly on the base. Make sure it is resting properly on the base.
2. The Ringer Volume Control may be set to OFF. Adjust the switch to LO or HI. (The flashing ring indicator always indicates a call being received.)
3. Too many phones or phone devices may be connected to the same line. If so, remove other phones or devices from line.
4. Your older extension phone may cause the PhoneMax to cut off. If so, install Williams Sound's optional Equalizer Phone Accessory (TEL 007) in the line to the older phone. The Equalizer balances the amount of phone line current drawn by older phones using the same line as the Phonemax.

Warranty

Williams Sound Products are engineered and manufactured to give many years of trouble free service. Occasionally, latent defects will occur. If this happens, call the phone number below and request a Return Authorization (RA) number. After getting this authorization, return the product to us with shipping cost prepaid and advise us by letter of the observed difficulty.

During the first five years following the date of purchase, we will promptly repair or replace the product and return it at our expense. After five years from the date of purchase, we will service our products for a modest service charge. Please return the enclosed warranty card to register your date of purchase.

This warranty does not extend to intentional or accidental physical damage. Cords are warranted for 90 days. This warranty applies only to products returned to Williams Sound for service.

Unauthorized modifications or repairs of the product will void the warranty.

Williams Sound Corp.
10399 West 70th Street
Eden Prairie, MN 55344-3459

Phone: 1-800-843-3544 / 1-612-943-2252

Fax: 1-612-943-2174

TTY: 1-612-943-9675

Web: www.williamssound.com

E-mail: info@williamssound.com

SPECIFICATIONS

PhoneMax Amplified Telephone, Model TEL 030

Dimensions:	2.2" D, 8.9" H, 7.6" W (56mm D, 226mm H, 192mm W)
Color:	White with dark gray controls
Wide-band Acoustic Gain:	17 dB maximum
Max. HF Acoustic Gain:	25 dB
Audio Freq. Response:	300 Hz to 2800 Hz, \pm 3 dB
Saturated Acoustic Output:	112 dB SSPL
Total Harmonic Distortion:	< 3% at 105 dB SPL output, 1000 Hz
Signal to Noise Ratio:	51 dB, NAB Weighted
Ringer Volume Control:	Hi, Lo, Off
Ringer Loudness:	80-85 dBA SPL at 1 meter (Hi position)
Ringer Pitch Control:	Adjustable, 3 positions (lo, med, hi)
Flasher:	High visibility red neon lamp
Connections:	2-wire central office connection, modular plug
Ringer Equiv. Number (REN):	1.0B
Warranty:	Five Years, Parts and Labor*

* 90 days on cords and connectors

FCC Registration Notice

Your new PhoneMax product has been registered with the Federal Communications Commission (FCC). This product complies with standards in Part 68 of the FCC Rules. The FCC requires us to provide you with the following information:

1. Connection and use with the nationwide telephone network
The FCC requires that you connect your product to the nationwide telephone network through a modular telephone outlet or jack. The modular telephone outlet or jack to which the telephone must be connected is a USOC RJ-11C or RJ-11W.
This equipment may not be used with Party Line Service or with Coin Telephone Lines.
2. Notification to the telephone company
The FCC requires that upon request of your local telephone company, you provide the following information:
 - A. The 'line' to which you will connect the telephone equipment (your phone number).
 - B. The telephone equipment's FCC registration number and Ringer Equivalence Number (REN). These numbers are on the back or bottom of your telephone equipment.
The REN is useful to determine how many devices you may connect to your telephone line and still have them ring when your telephone line is called. In most, but not all areas, the sum of all REN's should be 5 or less. You may want to contact your local telephone company if you experience problems.
3. Repair instructions
If it is determined that your telephone equipment is malfunctioning, the FCC requires that it not be used and that it be unplugged from the modular outlet until the problem has been corrected. Repairs to this telephone equipment can only be made by the manufacturer or its authorized agents or by others who may be authorized by the FCC. For repair procedures, follow the instructions under the section entitled Warranty.
4. Rights of the telephone company
If your product is causing harm to the telephone network, the telephone company may temporarily discontinue your telephone service. If possible, they will notify you before they interrupt service. If advance notice isn't practical, you'll be notified as soon as possible. You'll be given the opportunity to correct the problem, and you'll be informed of your right to file a complaint with the FCC.
Your telephone company may make changes in its facilities, equipment, operations, or procedures that could effect the proper functioning of your PhoneMax product. If such changes are planned, you'll be notified.
5. This telephone is compatible with inductively coupled (Telecoil) hearing aids.

Interference Information: Part 15 Of FCC Rules

Some telephone equipment generates and uses radio-frequency energy and, if not installed properly, may cause interference to radio and television reception.

Your PhoneMax product has been tested and found to meet the standards for a Class B computing device, as specified in Subpart J of Part 15 of the FCC Rules. These specifications are designed to provide reasonable protection against such interference in a residential installation. However, there is no guarantee that interference will not occur in a particular installation.

If your PhoneMax product causes interference to radio or television reception when it's in use, you might correct the interference with any one of these measures.

1. Where it can be done safely, re-orient the receiving telephone or radio antenna.
2. To the extent possible, relocate the television, radio or other receiver with respect to the telephone equipment.



Williams Sound Corp.

10399 West 70th St., Eden Prairie, MN 55344-3459
U.S.A. 800-328-6190 / 612-943-2252 / FAX: 612-943-2174
www.williamssound.com / info@williamssound.com

© 1999, Williams Sound Corp. MAN 096A